

BULLETIN NUMBER: SP8009-0812

DATE: 8/25/08

SUBJECT: Short Burst of Water on Power-Up

MODELS: Automatic Water Fill Steamers

SERIAL NUMBER: Prior to 26508



NOTICE

THIS DOCUMENT CONTAINS INFORMATION PROPRIETARY TO ACCUTEMP PRODUCTS, INC. AND IS TO BE USED ONLY BY AUTHORIZED SERVICE PERSONNEL. DUPLICATION OR REPRODUCTION OF THIS DOCUMENT IN ANY OTHER FORM, IN WHOLE OR IN PART, IS STRICTLY PROHIBITED

Background

For auto-fill and Evolution steamers with serial numbers prior to 26508, the water level sense PCB was not powered up until the steamer was turned on. As a result, a ten-second burst of water was injected into the reservoir as the steamer was turned on, even if the water reservoir was full. An over-fill condition could occur if the power was cycled frequently, causing multiple ten-second bursts of water each cycle. A solution is to power the water sense PCB continuously, so it will be monitoring the water level, even when the steamer is turned off. This will prevent the momentary ten-second burst of water during power up, when the water reservoir is full.

Field Corrective Action

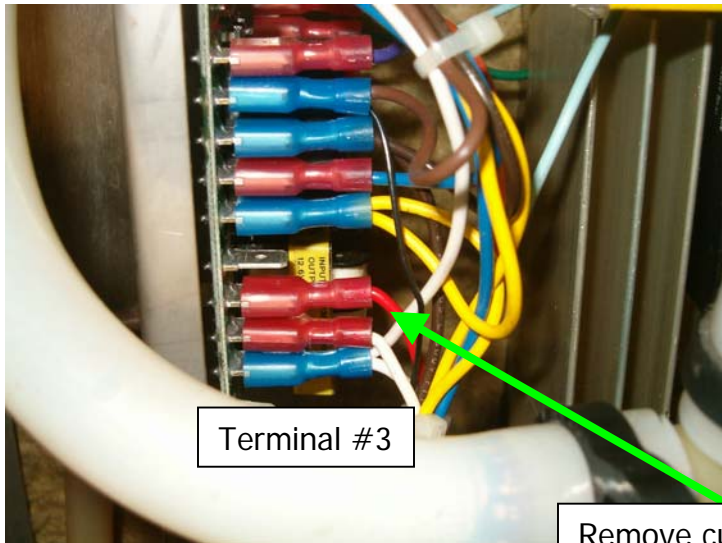

Fig. 1

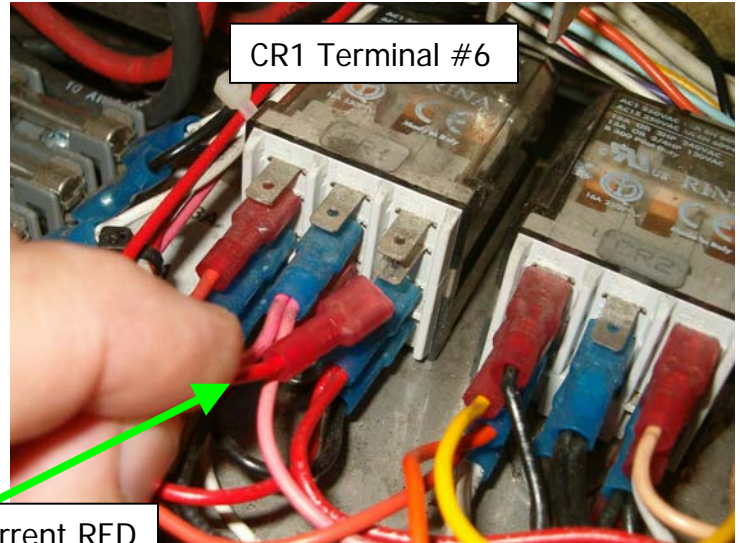
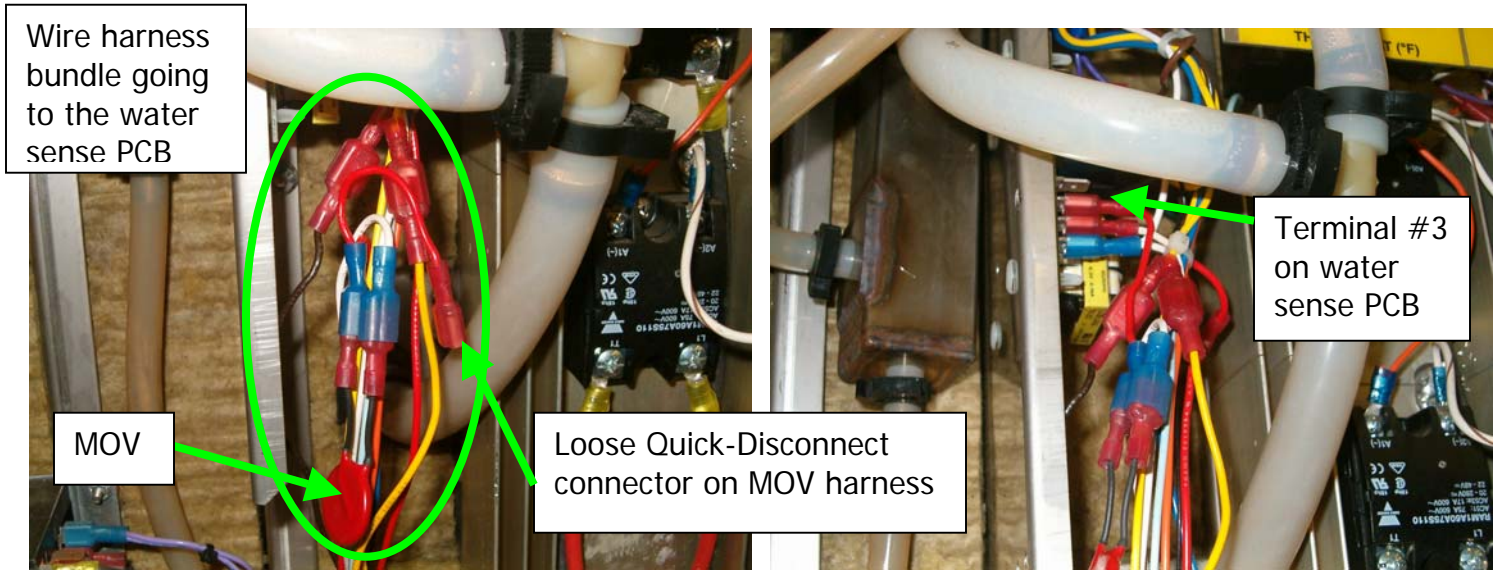

Fig. 2

Remove current RED wire power harness

CAUTION!!!! Power down and disconnect the steamer from the power outlet before proceeding!

- 1) Disconnect the current RED wire harness connection on terminal #3 of the water sense PCB (see Fig. 1).
- 2) Disconnect the current RED wire harness connection on terminal #6 of the CR1 control relay (see Fig. 2).



3) Locate the loose Quick-Disconnect connector on the end of the RED wire harness that is attached to the MOV. It will be tucked into the wire harness bundle (see Fig. 3).

4) Insert the Quick-Disconnect connector of the RED wire harness that is attached to the MOV, onto terminal #3 of the water sense PCB (see Fig 4.).

5) Reconnect the steamer to the power outlet.