

N6 DBL CONNECTIONLESS EVOLUTION
2 Double Stacked. Stand-Mounted 6 Pan,
Natural Gas Boilerless Convection Steamers

Project: _____ Location: _____ Item #: _____ Quantity: _____

Standard Features

- Fast cook times with patent-pending Steam Vector Technology, which utilizes no moving parts
- Cook mode and Variable Temperature Hold mode
- Steamer powered by a Heavy Duty Stainless Steel Blue Flame Power Burner rated at 60,000 btu/hr
- Easy-to-use digital controls, with digital temperature display
- Independent digital electronic timer with programmable preset
- Simple water and drain connections
- No water filtration or treatment required
- No warranty exclusions for water quality
- Uses less than 1 gallon of water per hour
- Front-mounted drain valve
- Specify Altitude if over 2,000 ft above sea level
- Internal gas regulator
- No scheduled de-liming or maintenance
- Heavy-duty, field-reversible door
- Door can be opened at any time during cooking cycle
- Steamer cavity constructed of reinforced 14 ga. 304 stainless steel
- Easy-to-clean control panel
- Automatic altitude compensation
- Dishwasher-safe one-piece wire pan racks
- Dishwasher-safe SVT steam collector and distributor panels
- Front-mounted condensate tray
- English and Spanish operating instructions on door
- Simplified service access panel
- Low water, high water and overtemp indicator lights
- (2) 5' power cords and plugs included, separate receptacle needed for each unit
- One year parts and labor warranty
- Lifetime Service & Support Guarantee
- UL LISTED Safety Certification (ANSI Z 83.11)
- UL EPH Sanitation Certification (NSF 4)

Optional Features

- Stainless steel support stand available with casters, bullet feet or flanged feet
- Perforated cooking shelf
- Propane

Environmental Approvals & Programs



Other Approvals



Pan Capacities - per cavity

Pan Size	Qty.
#200 full size (12x20x2.5")	6
#400 full size (12x20x4")	4

Short Spec

Evolution steamer is AccuTemp Products' connected, boilerless steam cooker that utilizes AccuTemp's Patent Pending Steam Vector Technology for faster cook times, improved energy efficiency, better pan to pan uniformity, and less water consumption. Steam Vector Technology requires no moving parts inside the cooking chamber. Steam to be produced inside the cooking cavity with no heating components exposed to water. Unit to be powered by a Heavy Duty Stainless Steel Blue Flame Power burner, Easily connects to water, drain & gas lines. Uses less than 1 gallon of water per hour. Unit to include low water, high water, overtemp warning lights and auto shut off feature. Evolution to include heavy duty, field reversible door. Standard digital controls with independent timer. No water quality exclusions to warranty and no water filtration or treatment required. Units to be mounted on a stainless steel support stand. Unit to be UL Safety and Sanitation Certified, and Energy Star qualified. Built in USA.



N6 Evolution Models shown with optional drain pan and stand with casters

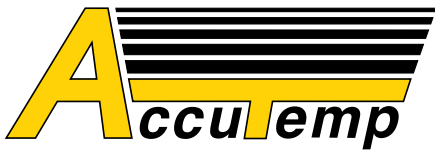

N6 DBL CONNECTIONLESS EVOLUTION

2 Double Stacked. Stand-Mounted 6 Pan,
Natural Gas Boilerless Convection Steamers

Gas Steamer Model Specifications per cavity DBL = TWO CAVITIES		
Model #	N61201D DBL	P61201D DBL
Gas Supply	Natural Gas	Propane
Recommended Gas Feed Rate	5" wc min 14" wc max	12" wc min 14" wc max
Gas operating Pressure	5.0" wc	10.0" wc
Maximum input BTU's/hr	60,000	60,000
Electrical Powered	120v, Single Phase, 60hz, 1 AMP	
NEMA Plug	5-15 three prong plug	

Notes:

1. Allow 3" between fryer, ranges, and other hot surfaces.
2. Each unit equipped with 5' power cord with NEMA 5-15 three prong plug, 120v, single phase, 60hz, 1 AMP.
3. For use on individual branch circuits only.
3. Each unit equipped with 1/2" NPT Threaded Natural Gas Connection.
4. Dimensions outside brackets are inches, in brackets are millimeters.
5. This appliance not intended for household use.
6. Units equipped with internal Gas Regulator.

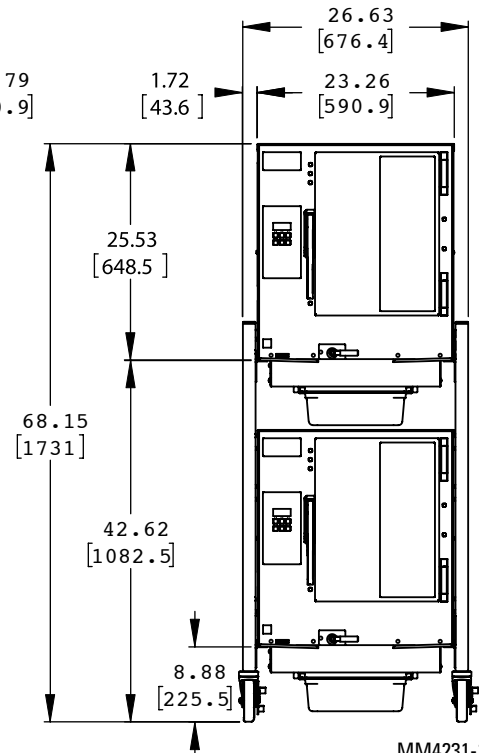
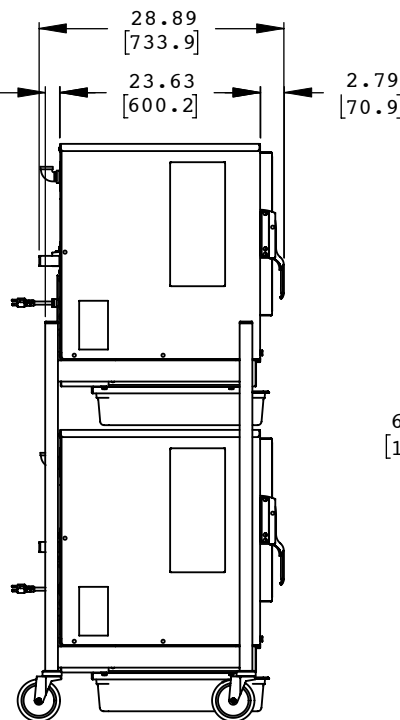
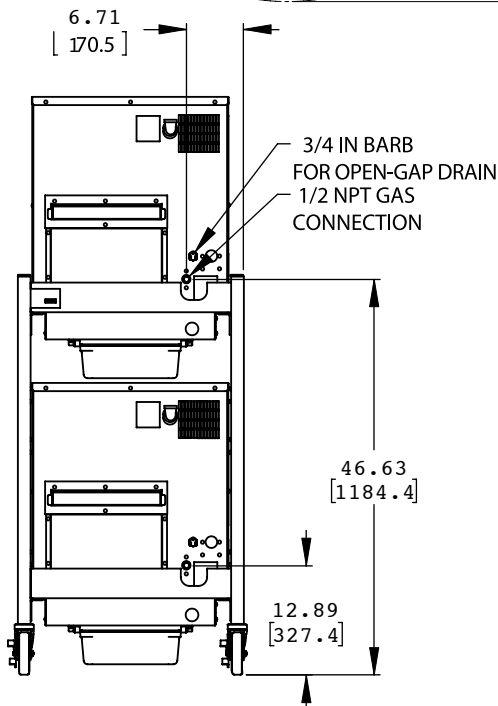
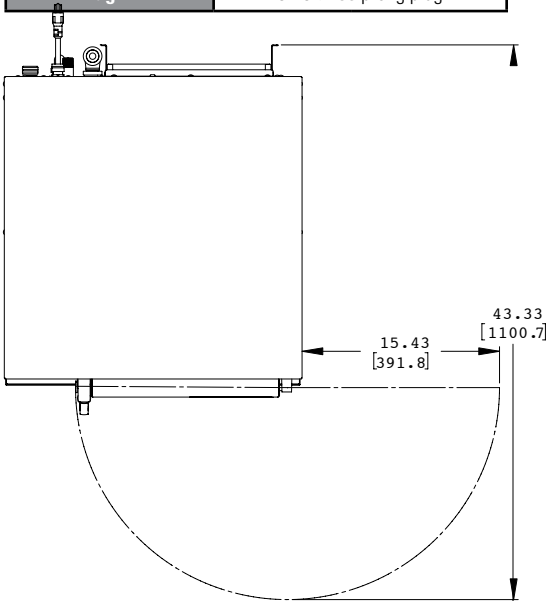
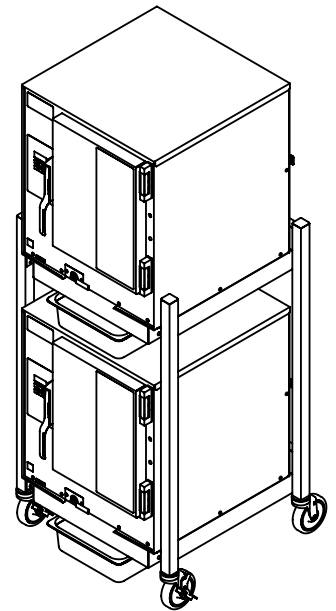

MM4231-1003

AccuTemp Products, Inc.

8415 North Clinton Park • Fort Wayne, IN 46825 • 800-210-5907 • 260-493-0415 • Fax 260-493-0318 • accutemp.net