



# ACCU-STEAM™ COMPACT DROP-IN GRIDDLE

## Electric/Steam-Heated, Drop-In Griddle

### Short Specification

Griddle shall be an AccuTemp Compact Drop-In Model. 14" x 18" 208V modular drop-in electric heated unit, with hermetically- sealed vacuum chamber that produces steam to heat the 8-gauge stainless steel griddle plate. Efficient steam heat transfer provides 200–400°F (93–204°C) operating temperature range and uniform griddle surface temperatures of ±3°F (±1°C). Unit features all stainless steel construction and incorporates a new "drawn" manufacturing process that provides a generous full perimeter radius and aesthetically pleasing cooking surface recessed 1/4" below the cabinet or table top mounting surface. This unit is available with an optional full width 3" by 1" deep grease trough module, with drop to an enclosed grease drawer. A solid-state thermostat controls the operating temperatures and never requires calibration.

### Construction Features

- All stainless griddle module insulated and sealed for easy installation in new or existing cabinet or work station
- Sealed control panel provided for cabinet front mounting

### Performance Features

- Hermetically-sealed steam/vacuum chamber mounted to and below griddle cooking surface
- 16.67-kW power input, with long-life low watt density heating elements mounted inside vacuum chamber and immersed in chemically pure water. (Water never needs replacement)
- Steam transfers heat evenly to cooking surface with only ±3°F (±1°C) in temperature variation
- Rapid surface temperature recovery (10 seconds or less) allows turning product to same spot when grilling
- Smooth cold-rolled stainless steel griddle surface speeds and simplifies cleaning
- 1/4" recessed cook surface reduces splatter and cleanup of surrounding work surface

### Standard Control Features

- Modular sealed control panel reduces grease infiltration and chance of flare-ups
- Power-On switch & indicator light
- Heating indicator light
- 200–400°F (93–204°C) solid state thermostat
- Easy front service access to all controls

### Griddle Applications include

- Pancakes, Eggs, Sausage, French Toast
- Burgers, Grilled Onions, Toasted Buns
- Grilled Cheese, Monte Cristo & Ruben Sandwiches
- Fried Potatoes, Fish, Chicken Breasts, Sandwich Steaks, Liver and MORE

### Approvals

- Griddle to be NSF Listed
- Griddle to be U.L. Listed



### Installation Requirements

- ☐ 208/3 Power Source (See other side for AMP requirements.)
- Easy inter-module connection, with two cables provided
- Single main power connection required



EGD-21 Compact Drop-In Model Cook Top & Control Modules Shown



EGD-21 Compact Drop-In Model Cook Top Shown with Optional Grease Trough



# ACCU-STEAM™ COMPACT DROP-IN GRIDDLE

Electric/Steam-Heated, Drop-In Griddle

EG Series Griddle Specifications	
Model	EGD-21
KW Input	16.67 kW
208/3 Amp Load	13.3
Unit Width	20.51" [521 mm]
Cooking Width	17.66" [449 mm]
Cooking Depth	14.16" [360 mm]
Effective Cooking Area	250 sq.in.

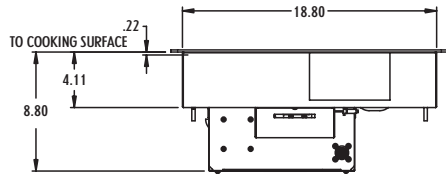
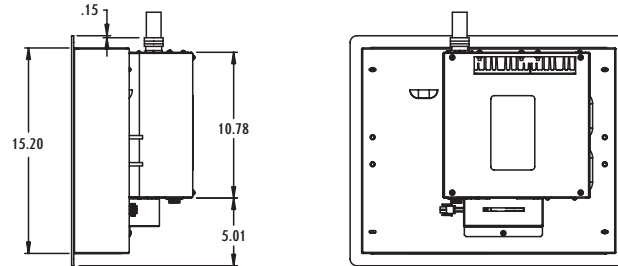
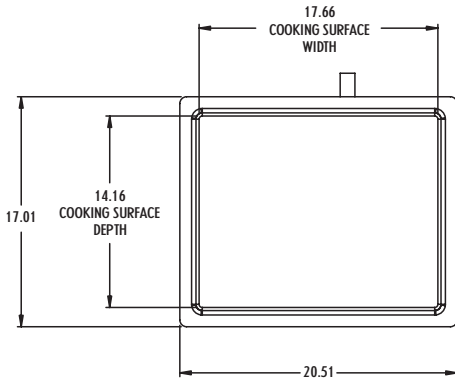
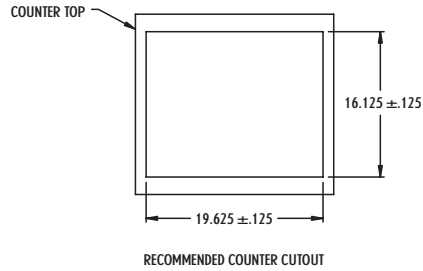
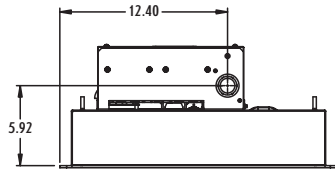

COMPACT GRIDDLE MODULE

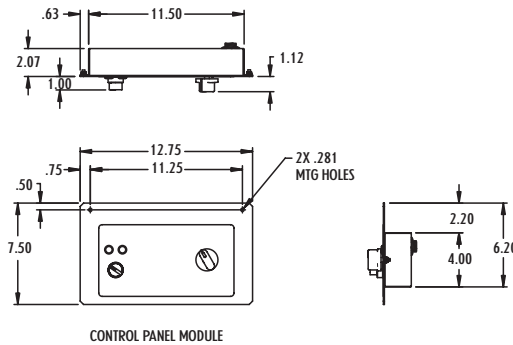

CONTROL PANEL MODULE

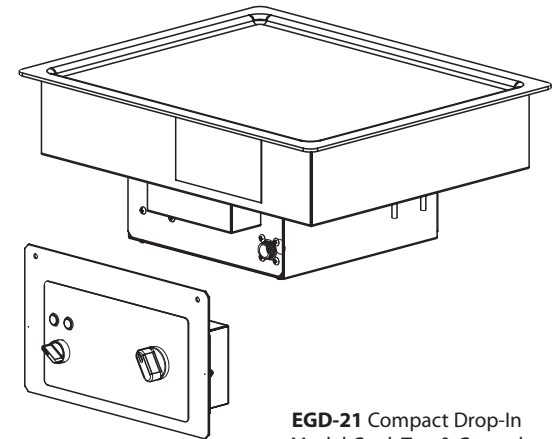

EGD-21 Compact Drop-In Model Cook Top & Control Modules Shown