

Project: _____ Location: _____ Item #: _____ Quantity: _____

Standard Features

- #304 heavy gauge stainless steel interior and exterior.
- Touchscreen Controls– Intuitive, easy-to-use 8" display panel works under all conditions with fast response, including with gloved or greasy hands, with no mechanical elements, dials, or buttons.
 - My Vision™ – features ability to customize your display menu.
 - Holds up to 1000 recipes, with up to 20 steps per program.
 - Multi-Tasking feature allows you to edit, change, and add recipes during the cooking cycle.
 - Manual, Easy Cooking, Favorites, and Last 10 modes for added operational efficiency.
 - Free Vision™ Combi software program.
- Advanced Steam Injection System – Two step water preheating with integrated heat exchanger raises incoming water to 130°F for perfect steam saturation while significantly reducing energy and water consumption.
- Water Saving System – Smart waste water system design requires minimal amount of water for cooling the exhaust steam.
- Advanced Humidity Control – for precise automatic humidity control from 1- 100%.
- Cooking Modes:
 - Steam 86-266°F
 - Hot Air 86-572°F
 - Combi 86-572°F
 - Proofing 86-572°F
 - Delta T, Cook and Hold, and Overnight Cooking.
 - Golden Touch – adds crisp, finishing touch.
 - Retherm/Banqueting presets
 - Continuous cooking option saves time during peak periods.
- Automatic Capacity Manager – self regulates, senses load and temp drop, then starts cooking when chamber at correct temperature.
- Multi-Point Probe.
- 7 Speed, Auto-Reversing Fan.
- Automatic Fan Stop promotes staff safety when door is opened quickly.

- Multi-Rack Timer.
- Tempered triple-pane, cool to touch, 2-step safety, curved glass door combined with special 2" insulation around cooking chamber.
- Flap Valve design – patented design for dehumidification for great color and results.
- Automatic Cleaning System with 5 cleaning levels and automatic cool down.
- Hand shower included.
- Integrated stainless steel door drip tray
- Preheat, Auto-Cool Down, Delayed Start, and Sleep modes.
- Diagnostics
 - Service Diagnostic System for easy unit check-up and troubleshooting.
 - Hinged front service panel provides easy access to all service diagnostics.
 - HACCP Data Protocol
 - USB port
 - LAN interface connection
- Pan capacity - 10 - 13x18" Sheet Pans or 10 - (2 1/2" deep)12x20" Hotel Pans.

Short Spec

Combi oven shall be AccuTemp model T1011IE Vision™ Touch Series with Advanced Steam Injection System with built in heat exchanger. Constructed of heavy duty #304 stainless steel with heavy duty 2" insulation and triple-pane, tempered, curved glass door, right hinged standard. Operation modes include: steam, hot air, combination, and proofing with Golden Touch finishing feature. Vision™ Touch includes My Vision™ customizable control panel, Active Humidity Control with 0-100% humidity levels, Automatic Capacity Manager, 7 speed auto-reversing fan, patented Flap Valve, multi-point probe, multi-rack timers, preheat and auto-cool down, automatic fan stop, and Multi-Tasking function. Automatic cleaning cycle with 5 cleaning levels and hand shower. Service Diagnostic System, for unit check-up, service, and troubleshooting, USB port, and HACCP data records. Ecologix technology for lower energy and water usage.



T1011IE Model shown

Accessories & Options

- Water Filtration System
- NEMA Plug Assembly
- Additional Wire Racks
- Stacking Kits & Stands
- Grill Pan
- Pizza/Baking Pan
- Egg Pan
- Air Fry Basket
- Active Cleaner
- Active Descaler

Approvals



- EPA 202 Evaluated / NFPA 96 4.1.1.2 Compliant

Combi Oven Model "T1011E" Specifications						
T1011E	Shipping Weight 397 LB 180 Kg	Voltage (V)	Phase (Ø)	Power (kW)	Amperage (A)	NEMA Plug (optional)
		208	3	15.3	43.8	15-50P
		240	3	20.1	49.8	15-50P
		480	3	18.6	23.0	L16-30P

It is the sole responsibility of the owner/operator/purchaser of this equipment to verify that the incoming water supply is comprehensively tested and if required, a means of "water treatment" provided that would meet compliance requirements with the water quality standards published below. Non-compliance with these minimum standards could potentially damage this equipment and/or components and VOID the original equipment manufacturer's warranty.

TWO (2) TOTAL COLD WATER INLETS -Drinking Quality
-ONE (1) TREATED WATER INLET: BSPP to 3/8" hose
-ONE (1) UNTREAT INLET: BSPP to 3/8" hose
WATER DRAIN: 2" connection

Inlet Pressure	40 - 80 PSI	Alkalinity (as CaCO3)	< 60 ppm (mg/l)
Free Chlorine	< 0.1 ppm (mg/l)	Chlorides	
Total Chloramine	< 0.1 ppm (mg/l)	(Sulfate+Chlorida+Nitrate)	< 40 ppm (mg/l)
pH Level	7.0 - 8.5 pH	Iron FE	< 0.1 ppm (mg/l)
Total Dissolved Solids	< 150 ppm (mg/l)	Silica	< 13 ppm (mg/l)
Water Hardness	< 90 ppm (mg/l)		

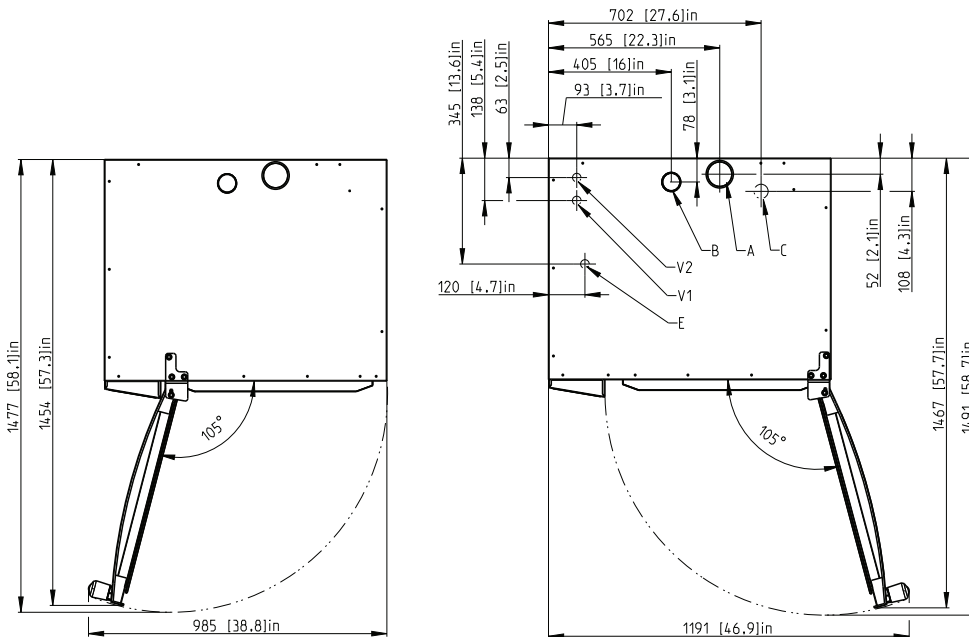
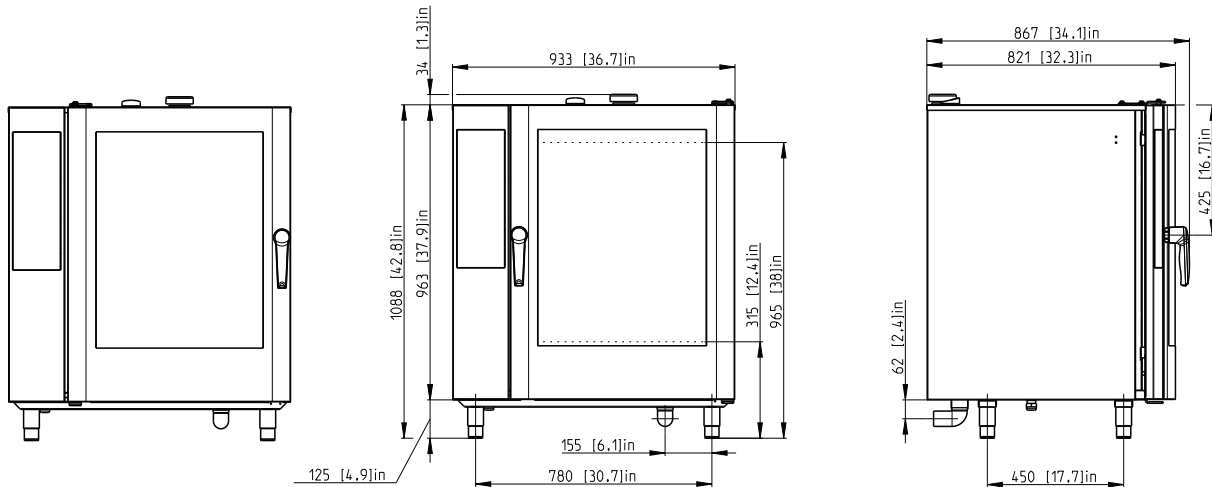

A - Air Intake
 B - Exhaust
 C - Drain
 E - Electrical Connection
 V1 - Unfiltered Water
 V2 - Filtered Water

Minimum Safety Clearance Requirements*	
Left Side	14" Recommended for Service Access
Right Side	2"
Rear	2"
Top	30" for air movement
Bottom	5"

* minimum of 20" from any heat source