



EVOLUTION ELECTRIC SERVICE MANUAL



ACCUTEMP PRODUCTS INC

8415 N. CLINTON PARK DR, FORT WAYNE, IN 46825 - 800 480-0415 - www.accutemp.net

REVISION SHEET

Current Revision: 1909
Date: 09/18/2019

Prior Revision:1203
Date: 03/31/2012

Change:
Revision and update

1. Exceeding the temperature limits can cause nuisance lockouts and premature electrode failure.
2. Alteration to Cast Heater Replacement and Removal instructions
3. Updated Troubleshooting flowchart.

TABLE OF CONTENTS

Warnings and Cautions	4
1.0 Sequence of Operation	7
1.1 Water Level System	7
1.2 Heat Generation	8
1.3 Temperature Sensor and Control board	9
2.0 Main Component Information	10
3.0 Troubleshooting Flowchart	13
3.1 Troubleshooting Table	14
3.2 Troubleshooting Notes	25
3.3 Modifying Control Settings	26
3.4 Location of Electrical Components	28
3.6 Recommended Tools	29
4.0 Removal and Replacement of Components	
4.1 R&R of Supply Power Components	30
4.2 R&R of Water Level Control Components	32
4.3 R&R of Heat Control Components	36
4.4 R&R of Cast Heater	38
4.5 R&R of Door Assembly	43
4.6 R&R of Temperature Sensors	47
4.7 Steam Vent Components	48
5.0 Wiring Schematics	
5.1 Wiring Schematic for SN 36980 and Below	50
5.2 Wiring Schematic for SN 36981 and Above	51

WARNING SYMBOL DEFINITIONS

SYMBOL DEFINITIONS

Symbols are used to attract your attention to possible dangers. They are only effective if the operator uses proper accident prevention measures. Some of the symbols are boxed text; while others maybe just picture icons. Please give this information the respect they deserve for safe operation.

Symbol Icons

Below are definitions of the symbol icons used in this manual.



DANGER

Indicates an imminently hazardous situation; which, if unchanged, will result in death or serious injury.



CAUTION

Indicates a potentially hazardous situation; which, if unchanged, will result in minor or moderate injury.

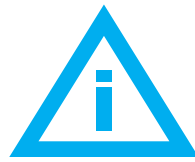

NOTE

Advises the reader of information or instructions, vital to the operation or maintenance of the equipment.



CAUTION - HOT SURFACE



DANGEROUS VOLTAGE

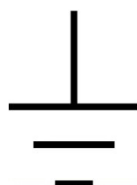

EARTH GROUND

SAFETY PRECAUTIONS



ELECTRICAL SHOCK HAZARD WHILE WORKING ON ENERGIZED EQUIPMENT.

Unplug equipment prior to removing any components effected by electricity.

BURN HAZARD WHILE WORKING ON STEAM PRODUCING EQUIPMENT.

When accessing the cooking chamber, be sure to always stand back while slowly opening the door to allow the chamber to vent off the steam. Never reach into the cooking chamber before it has completely vented off the steam.

Never reach into the cooking chamber or handle hot items without wearing the proper heat protective gloves. Steam coming out of the holes on the right side of the cooking chamber is invisible and can cause severe burns.

Water inside the steam chamber, creating steam, has a temperature of 212°F and will cause burns if touched or spilled on the skin.

PERSONNEL INJURY HAZARD WHILE PICKING UP OR MOVING HEAVY EQUIPMENT.

Always use 2 people and proper lifting techniques when picking-up, moving, or inverting heavy equipment.

SLIP & FALL HAZARD WHILE WORKING ON WATER HOLDING EQUIPMENT.

Keep the floor in front of the equipment clean and dry. If spills occur, clean them up immediately to avoid potential injuries.

WARNING & CAUTION NOTES



ONLY QUALIFIED SERVICE TECHNICIANS SHOULD PERFORM MAINTENANCE ON THIS EQUIPMENT.



- **DO NOT** use abrasive or steel materials, such as wire brushes or metal scouring pads to clean the Water Sensors.
- **DO NOT** manually fill water above the Water Level Mark on the left side of steam chamber above the High Limit Level Sensor (connection-less only).

1.0 Sequence of Operation

1.1 WATER LEVEL SYSTEM & INDICATOR LIGHTS:

PWR Button Pushed & Water Level Is Below the Low Water Level Sensor - AUTO-FILL

- The Low Water Light Indicator will be lit.
- PRE is displayed on the Control/ Keypad Board.
- The Water Sensor Board sends a signal to the Water Sensor Board's K1 Relay to open the Auto-Fill Valve and start filling the steam chamber with water.
- The red LED light on the Water Sensor Board will be flashing continuously.

PWR Button Pushed & Water Level Is Below the Low Water Level Sensor - MANUAL FILL

- The Low Water Light Indicator will be ON and Alarm will sound.
- PRE is displayed on the Control/ Keypad Board.
- The red LED light on the Water Sensor Board will be flashing continuously.

PWR Button Pushed & Low Water Level Sensor Is Satisfied - MANUAL & AUTO-FILL

- The Low Water Light Indicator and Alarm (only manual fill units use an alarm for low water condition), will be OFF.

- This is the minimum water level needed for the contactor to close and turn the Cast Heater ON.
- The red LED light on the Water Sensor Board will have about a 1 second flash delay.

Water Level Is At the High Limit Water Level Sensor - AUTO-FILL

- When the water level in the chamber touches the High Water Limit Probe, the Water Sensor Board will continue to activate the Auto-Fill Valve for an additional 30 seconds; and then turns the valve off. (This will occur every time the water level falls below the High Limit Probe).
- The red LED light on the Water Sensor Board will have about a 2 second flash delay.

Water Level Is Filled Too High in the Steam Chamber - AUTO-FILL

- The Float Ball rises on the Over-Fill Reed Switch sensor peg until the magnetic field from the Float Ball is above the Reed Switch, causing the Reed Switch to open. This causes the Control Relay #1 AC coil's voltage to drop, dis-engaging the relay from the steamer's normal operation; illuminating the High Water (Over-Fill) Indicator Lamp and sounding the buzzer.
- The loss of Control Relay #1 will remove the power signal to the Contactors control coil, which opens the contacts and prevents Line Voltage to the Solid State Relay(s). This stops the Cast Heater from generating heat.
- (To restart the steamer, open the Drain Valve to drain the water, until the High Water (Over-Fill) Indicator Light goes out. Press the PWR button ON to restart the start-up procedure.)

1.2 HEAT GENERATION:

Power Cord Plugged-In & PWR Button Not Pushed

- Line Voltage comes into the 3 Pole Contactor's L1 - L3 terminals. (Refer to the unit's specific wiring schematics to determine the wire color to "L" Terminal location.)
- Line Voltage is then taken off of L1 & L2 of the Contactor and applied to the Transformer, which steps-down the Line Voltage to 24VAC.
- From the two, 1.25Amp, fuses; power goes through the Overtemp Switch, then goes to the Water Sensor Board, to Control Relay #1 (CR#1) coil, to the High Water Overfill Reed Switch (Auto-Fill Only), to the Control/Keypad Board, and to Pin 6 of CR#1. Power also flows through CR#1, Control/Keypad Board, Water Sensor Board and Contactor (once the water level condition is met).
- (The red LED light on the Water Sensor Board will be flashing continuously.)

PWR Button Pushed & Low Water Level Sensor Is Satisfied

- (The red LED light on the Water Sensor Board will have about a 1 second flash rate.)
- The Water Sensor Control Board's K2 Relay will close, sending power to the Contactor's coil; closing the contacts and allowing Line Voltage to be sent to the normally open Solid State Relay(s).

- The Control/Keypad Board will send a 24VAC signal to the Solid State Relay(s); closing the Relay(s) (as long as the Door Switch and the Chamber Pressure Switch are closed).
- The Solid State Relay(s) then pass Line Voltage to the Cast Heater's Elements generating heat evenly over the bottom of the steam chamber; creating steam for cooking.
- In HOLD mode (HLD), the steamer's regulated temperature will change to the HOLD temperature's preset value. The Control/Keypad Board will regulate temperature via the RTD input, based on the current HOLD mode preset value. (This value can be changed using the program function on the Control/Keyboard Control.)

1.3 TEMPERATURE SENSOR (RTD) AND CONTROL/KEYPAD BOARD

- As the water temperature rises, the RTD will provide a signal, based on the resistance of the sensor, to the Control/Keypad Board to provide a digital temperature display.
- Control Panel will show PRE (Preheat) on initial start-up until the steam chamber reaches 195°F, then COO (Cook) will be displayed between 195°F and 212°F.
- The operating default mode on initial PWR ON is COOK mode; which automatically causes the steamer to go to the normal operating boiling point, which is 212°F at sea level.
- In COOK mode, the 24VAC output from the Control/Keypad Board is continuously on, so that the unit's temperature is controlled by the Chamber Pressure Switch, which opens at 1/2 inch of water column or higher.

2.0 Main Component Information

Component	Part #	Purpose
Transformer	<u>Assembly Part#</u> AT0A-5076-1 (below SN 52865) AT0E-2662-7 SN 52866 onwards)	<ul style="list-style-type: none"> Steps-down the Supply Line Voltage to 24 -28VAC.
Overtemp Switch (<i>Thermal Limit SW3</i>)	AT1E-2653-3 12kW & lower AT1E-2653-4 13kW & above	<ul style="list-style-type: none"> Normally closed switch that provides a safety feature to the machine in case the Element overheats. If the Element <u>overheats</u>, the switch will <u>open</u> and turn the steamer <u>off</u>; while lighting the red LED Overtemp Light on the Control Panel. The steamer will <u>not</u> turn on until the temperature has dropped enough to allow the Overtemp Switch to close again.
Control / Keypad Board	AT0E-3625-1-RXX (XX is software revision)	<ul style="list-style-type: none"> Human interface for steamer operations through push-buttons, operations, & display readouts. Provides power to the Solid State Relays Receives input from the Temperature (RTD) Sensor and displays the water temperature on the LED readout. Maintains the preset HOLD temperature.
Water Sensor Control Board	AT0E-3230-2	<ul style="list-style-type: none"> Receives inputs from Water Sensor Probes and implements corresponding actions for those inputs based on the water level in the steam chamber. Controls the Auto-Fill Valve (<i>if installed</i>) and receives inputs that provides actions for the desired water level needs.
Water Sensor Probe	AT1E-2652-1	<ul style="list-style-type: none"> Teflon exterior with a stainless steel center that uses the minerals in the water to complete the electrical circuit to the Water Board. MUST BE CLEAN TO WORK PROPERLY.
<i>Low Water Level Probe</i>		<ul style="list-style-type: none"> Once the Low Water Sensor is satisfied, it will allow the Main Contactor to activate. If the water level is below the sensor, the Water Board will activate the Auto-Fill Valve (<i>if installed</i>) filling the unit the water until the High Limit Water Sensor is satisfied.
<i>High Limit Water Level Probe</i>		<ul style="list-style-type: none"> On initial chamber water fill, once the water level reaches and satisfies the Operational Water Sensor, the Water Board will keep the Auto-Fill Valve open for 30 additional seconds.. After initial chamber water fill, when the water level drops below the sensor's operational level; the Water Board will open the Auto-Fill Valve for 30 seconds to raise the water level back above the High Limit Water Sensor. This process will repeat as long as the water level stays above the Low Water Sensor.

2.0 Main Component Information

Component	Part #	Purpose
Auto-Fill Valve (OPTIONAL)	AT1A-5192-1 (below SN 58694) AT1A-5185-1 (SN 58695 onwards)	<ul style="list-style-type: none"> Solenoid Valve that allows water to flow into the steam chamber; that is controlled automatically by the Water Board based on inputs from the Water Sensor Probes.
Water Over-Fill Sensor Switch (OPTIONAL)	<u>Reed Switch:</u> AT0A-3519-2 <u>Float Ball:</u> AT0P-3233-1	<ul style="list-style-type: none"> Magnetic Reed Switch is used in conjunction with a Float Ball. If the water rises too high, the switch opens and turns off the steamer. When the switch opens, the High Water Overfill LED will light. The user will have to drain the water out and turn the steamer back ON; otherwise, the steamer will remain shutdown.
Control Relay #1 (AC)	AT0E-2825-5	<ul style="list-style-type: none"> Controls AC Volt input & output signals which provide actions from the Water Sensor Board and Auto-Fill Valve (<i>if installed</i>).
Door Switch	AT0A-3660-1	<ul style="list-style-type: none"> Magnetic Switch used to ensure that the door is closed and latched prior to generating steam Solid State Relays will not activate if this switch is not closed (Door Open).
Chamber Pressure Switch	<u>S#: 34769 & Up</u> AT0E-3617-4 <u>S#: 34768 & Lower</u> AT1A-3847	<ul style="list-style-type: none"> Normally closed switch that allows pressure to build-up inside the steam chamber. Opens when the steam chamber pressure reaches 1/2" Water column Solid State Relays will not activate if this switch is not closed (Door Open).
Solid State Relay	AT0E-2059-3	<ul style="list-style-type: none"> Provides line voltage to the Cast Heater elements, once the Controller/Keypad Board sends the 24V control signal to the relay(s). The relay(s) are only activated if the Door Switch & Chamber Pressure Switch are closed. The number of Solid State Relays used, depends on the phase and wattage needs of the unit.

2.0 Main Component Information

Component	Part #	Purpose
Temperature (RTD) Sensor	AT0E-3626-1	<ul style="list-style-type: none"> Provides temperature input to Control/Keypad Board, which displays the temperature in the steam chamber based on resistance changes from the Temperature (RTD) Sensor. Used to maintain the preset HOLD mode temperature.
Door Assembly	AT1A-3600-1	<ul style="list-style-type: none"> Keeps the steam trapped inside the steam chamber to allow pressure to build and cycle the Chamber Pressure Switch.
Drain Valve	AT1P-2239-1	<ul style="list-style-type: none"> Manually Open/Close valve used to drain water from the steam chamber.
Cast Heater Replacement Kit	<p><u>6 KW:</u> AT1A-3530-1</p> <p><u>8 KW:</u> AT1A-3530-2</p> <p><u>10 KW:</u> AT1A-3530-3</p> <p><u>12 KW:</u> AT1A-3530-4</p> <p><u>14 KW:</u> AT1A-3530-6</p> <p><u>17 KW:</u> AT1A-3530-7</p>	<ul style="list-style-type: none"> Transfers the heat, generated from the internal elements; to boil the water to create steam. Cast Heater can be wired to single or 3 phase; and have a parallel, delta, or wye configuration. Cast Heater must be replaced with the same wattage heater as specified in the model number.

ADDITIONAL COMPONENT PART NUMBERS

Component	Part #	Component	Part #
Pilot Lamp, 24V Red	AT0E-1800-2	Inner Door Assembly	AT1A-3647-1
Fuse, Slo-Blo 1.25A	AT0E-2731-1	Door Hinge (Pair)	AT1H-2058-3
Door Latch Assy, Ceramic Magnet	AT1H-3609-1	Door Latch Mounting Plate	AT1M-3046-1
Gasket, Door	AT1G-2633-1		

3.0 Troubleshooting Flowchart

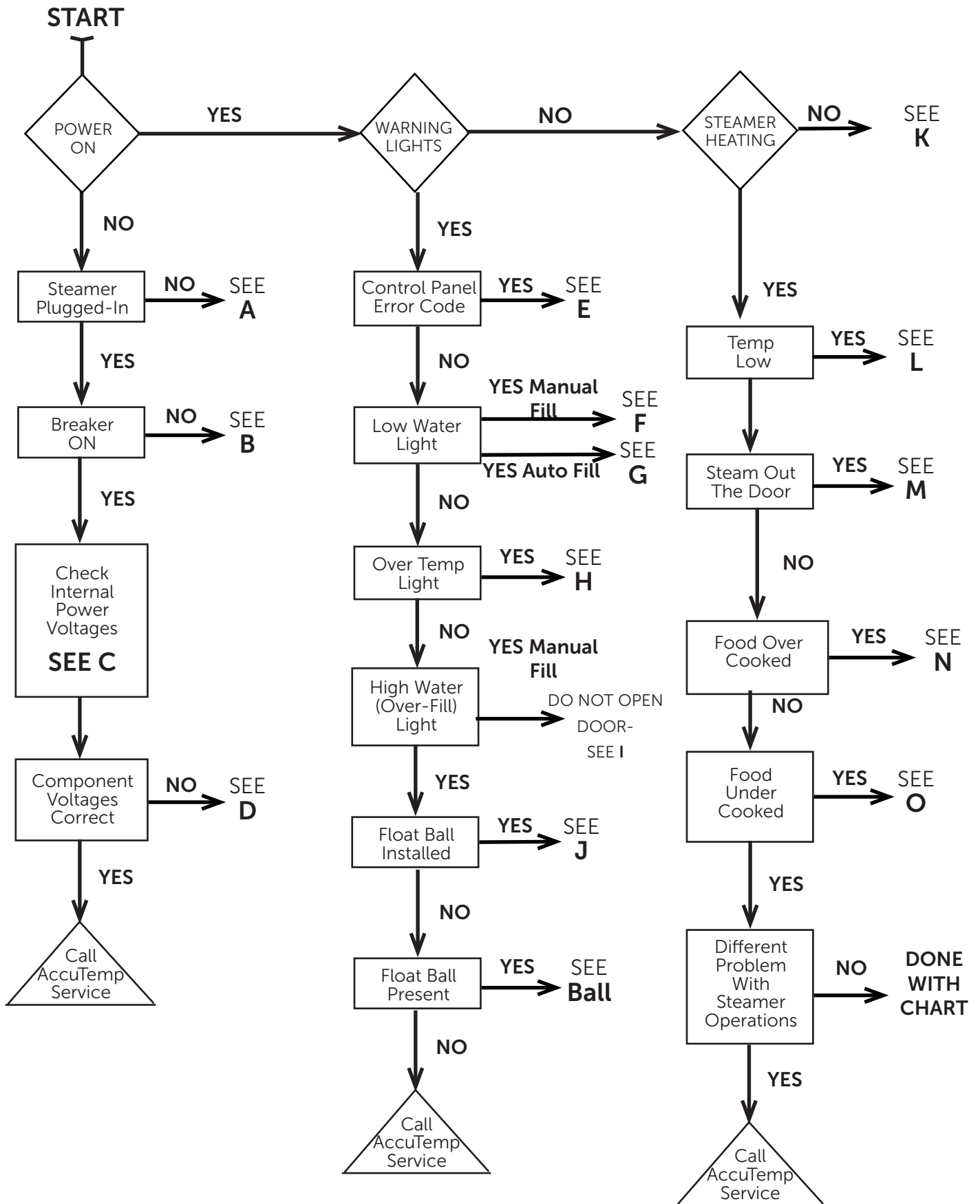

3.1 Troubleshooting Table

REF LETTER	POSSIBLE CAUSE	TROUBLESHOOTING STEPS
A	Power cord disconnected.	Confirm proper voltage is present at receptacle. Plug-in Power Cord.
	Power cord damaged/ broken.	Call Accutemp to confirm power to unit and secure correct part # for cord/plug assembly.
B	Breaker is tripped.	Reset breaker.
C	Transformer	Confirm supply has correct phase and incoming voltage on primary side. Confirm 24-32V output on secondary side. If no output on secondary, ohm between secondary terminals to check for shorted coil.
	Fuses (1.25A)	Test across fuses. Check for 24V across fuse. If 24V present across fuse, the fuse has failed.
	Overtemp Switch	If the overtemp switch is open - the overtemp alert light should be illuminated. To confirm failure, check for voltage between the Common wire attached to terminal #6 on Control Relay 1 (AC) and the common wire (yellow) on the transformers secondary side. If no voltage the overtemp switch is open
	Control Panel not responding to input.	Unplug the unit whenever disconnecting wires for the main control board. Check for incoming 24VAC on wires attached to J2-1 & J2-2 on the control board. If voltage is present, the control board has failed. When a failure on the board is confirmed - inspect the unit for water infiltration as a precaution against future failure.

REF LETTER	POSSIBLE CAUSE	TROUBLESHOOTING STEPS
D	Bad component voltages.	Check the wiring to the component; including wire-to-connectors, GND's, and damage. If a component output is bad, then it may need replaced.
E	Error Code: -1F or -99F for Temperature (RTD) Probe. EC: -1F = Open Temp (RTD) EC: -99F = Shorted Temp (RTD)	Inspect connection between RTD wires at J3-1 & 2 on control board. Any loose connections should be repaired/recrimped. Detach RTD wires from control board at J3-1 & 2. Ohm across wires while steamer is at room temp. RTD is a 1000 ohm sensor (see Fig.PG). If RTD ohms correctly replace control board, otherwise, replace RTD.
F	Low Water Sensor Not Satisfied	Water Sensors are steel studs circled by white teflon and are located inside cooking chamber on left hand wall towards unit front. Water sensors must be kept thoroughly clean. This should always be the first step with any water alarm. On a manual fill unit - ensure unit has been filled with water
	Water Level Board	An LED light on D3 will flash based on water level. Single second intervals indicate the water level board does not sense water A three second interval indicated the water level board is satisfied with the water level to allow for heating. If water board has three second interval and low water light is illuminated, remove pink wire at J9 on the water board. If the low water light goes out - replace water board. If light remains - call AccuTemp for assistance at 800-480-0415

REF LETTER	POSSIBLE CAUSE	TROUBLESHOOTING STEPS
G	Low Water Sensor Not Satisfied (Autofill) FIG 3.1A	<p>Water Sensors are stainless steel studs circled by white teflon and are located inside cooking chamber on left hand wall towards unit front.</p> <p>Water sensors must be kept thoroughly clean. This should always be the first step with any alarm</p>
	Water Level Board (Autofill) FIG 3.1B	<p>An LED light on D3 will flash based on water level. Single second intervals indicate the water level board does not sense water A three second interval indicated the water level board is satisfied with the water level to allow for heating.</p> <p>If the indicator light is flashing on a single second interval - the water board should close the K1 relay which provide power to the autofill solenoid valve and allow the unit to fill</p> <p>If unit is not filling remove the blue wire from J6 and the brown wire from J5. Test for AC voltage across the wires. FIG 3.1.C If AC voltage is present, connect the two wires together using a jumper wire. If the unit fills with the jumper in place - replace the water board. If the unit does not fill after bypassing the board, proceed to Auto-fill Solenoid. If voltage is not present, see below</p>
	Control Board	<p>Unplug the unit whenever disconnecting wires for the main control board.</p> <p>Disconnect the tan wire from J7-3 and the brown wire from J7-4. Connect the two wires using a jumper wire. Reconnect the unit to supply power. If contactor engages with board bypassed, main control board should be replaced.</p>
	Autofill Solenoid Valve FIG 3.1D	<p>Remove wires from the solenoid and test for 24VAC. If voltage is present, replace valve. If there is no voltage, see above to troubleshoot water board.</p>



FIG 3.1A

FIG 3.1B

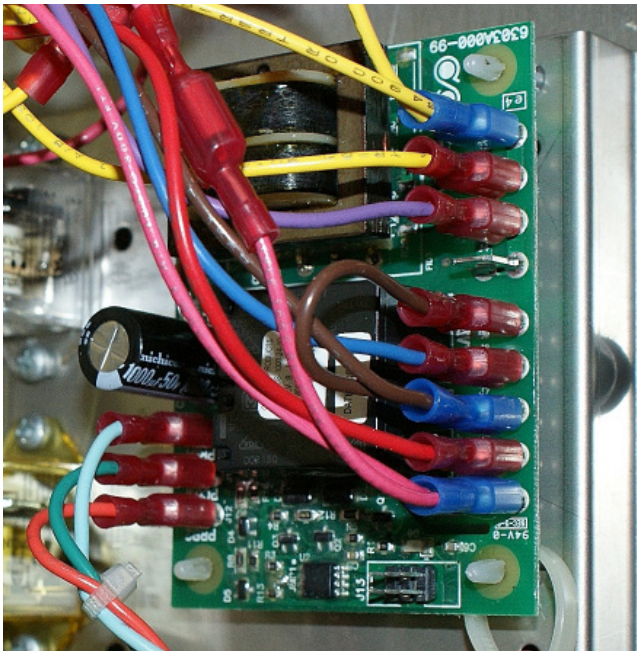

FIG 3.1D

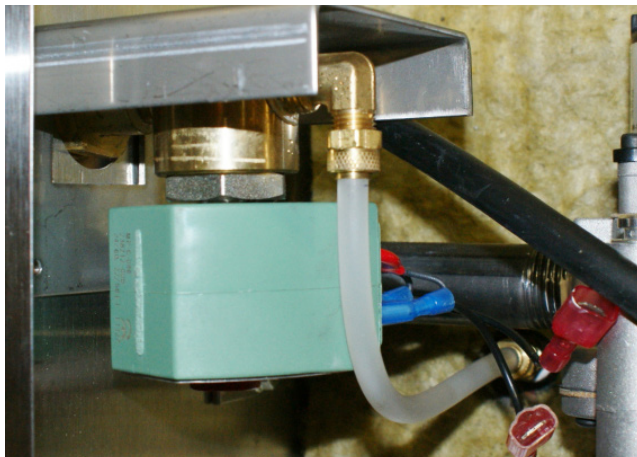
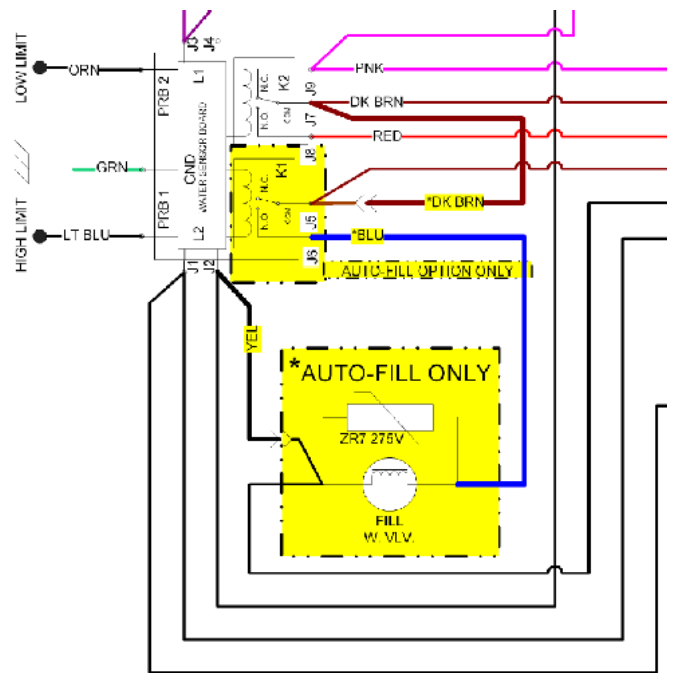
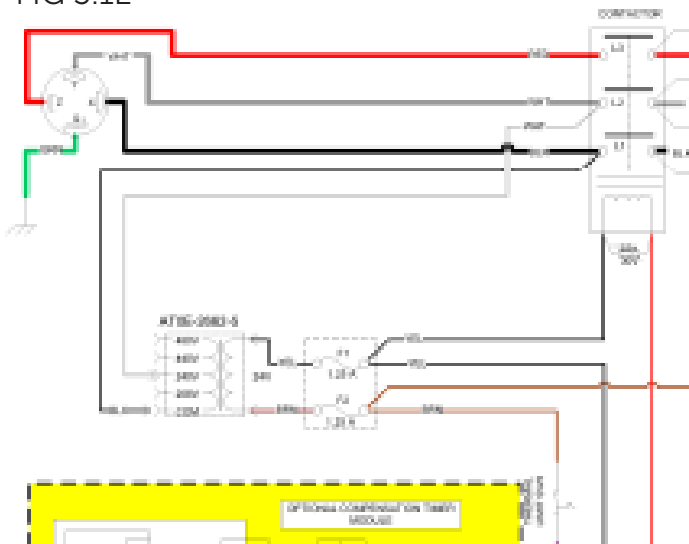

FIG 3.1C



REF LETTER	POSSIBLE CAUSE	TROUBLESHOOTING STEPS
H	Steamer Over-temp switch has opened.	<p>Ensure unit has water in it - if it does not, clean water sensors as indicated on page 17, fill and restart unit. If problem persists, see below:</p> <p>To confirm failure, check for voltage between the Common wire attached to terminal #6 on Control Relay 1 (AC) and the Common wire (yellow) on the transformers secondary side. FIG 3.1E If no voltage the over-temp switch is open.</p> <p>If unit shows overtemp alarm as soon as plugged in and the overtemp is confirmed to be open - replace over-temp switch</p> <p>Allow unit ten minutes to for unit to cool. Switch will reset automatically. Run unit from a cold start with fresh water. Once the unit has reached cook (Coo on display) ensure the heater begins to cycle on and off. If it does not - refer to reference letter K - pressure switch.</p> <p>If unit over-temps before it reaches cook: inspect bottom of cooking chamber (remove Steam Collector Pan first). Any scale build up should be cleaned away.</p>

FIG 3.1E



REF LETTER	POSSIBLE CAUSE	TROUBLESHOOTING STEPS
I	DO NOT OPEN DOOR!	Use drain valve to allow excess water to drain out until High Water alarm turns off. If alarm does not stop after draining all water - see below
	Control Relay 1 (AC) FIG 3.1F	Check for voltage across the violet wire attached to Terminal #7 and the yellow wire attached to Terminal #8. Disconnect wires to test. If voltage is present, ohm accross Terminals #7 and #8 on control relay with wires detached. Ohm reading should be 160 Approx. If voltage is not present, check output on secondary side of transformer.
J	DO NOT OPEN DOOR!	Turn the unit off. Use drain valve to allow excess water to drain out until High Water alarm turns off. If alarm does not stop after draining all water - see below
	Operational Water Sensor	Ensure that both the water probes are thoroughly clean. If not, clean and retry operation
	Installation Issues	Ensure the unit is level, front to back and side to side. An unlevel margin of 1/2" can create high water issues. This issue is more commonly seen in top steamers when part of a double stack. Remove Steam Collector Pan from bottom of cooking chamber. With the unit empty, observe the fill cycle. Is the water stream coming into the unit under high pressure? If the stream impacts the right hand wall of the unit, or close to, the incoming water pressure should be lowered. This must be done external to the unit.
	Float Ball FIG 3.1G	Confirm Float ball is in place and both it and the peg it sits on are clean. If there is another AccuTemp Steamer at the location, switch the float balls between the units. If the issue follows the float ball, replace the float ball.

REF LETTER	POSSIBLE CAUSE	TROUBLESHOOTING STEPS
J	Reed Switch	<p>The reed switch is located inside the sensor peg. With the float ball in place: Confirm continuity through the switch by testing at the Control Relay 1: Check for voltage across the violet wire attached to Terminal #7 and the yellow wire attached to Terminal #8. Disconnect wires to test (FIG 3.1G).</p> <p>If voltage is present - replace the control relay.</p> <p>If voltage is not present, replace the reed switch</p>

FIG 3.1G

FIG 3.1F

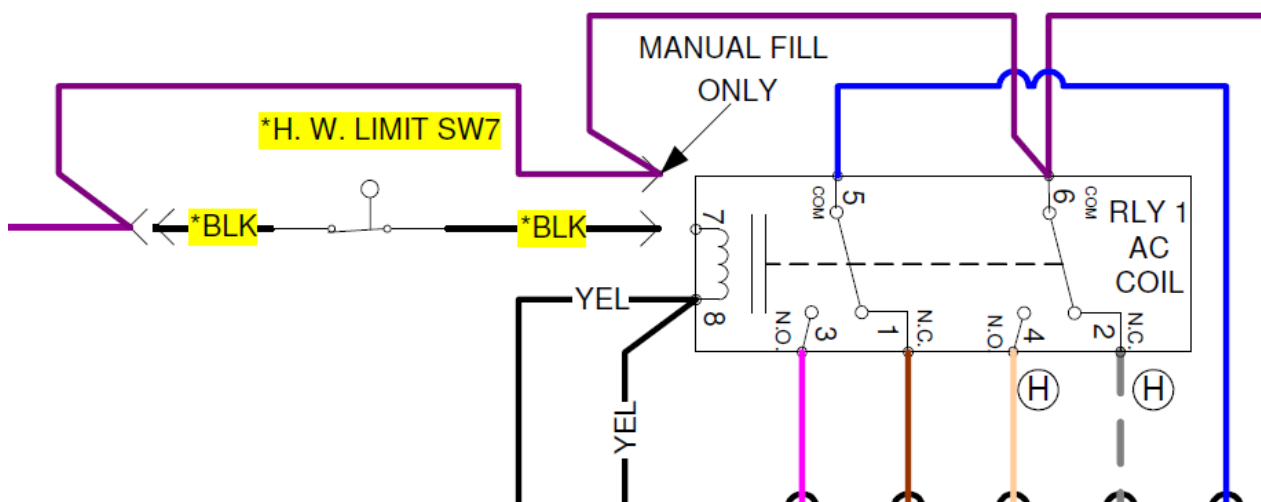

REF LETTER	POSSIBLE CAUSE	TROUBLESHOOTING STEPS
	Chamber Pressure Switch FIG 3.1H	Switch is normally closed. Disconnect wires from common and normally closed. Check for 24VDC between the wires. If there is not voltage see Control Board for further testing. If voltage is present, test for continuity across the common and normally closed terminals. If there is no continuity, open the door of the steamer. If there is still no continuity, replace pressure switch. If there is continuity, the steam vent requires cleaning.
K	Main Control Board	Unplug unit. With unit unplugged - remove red wire from Terminal #J7-1 and the Orange wire from #J7-2. Restore power to the unit. Carefully test for 24VDC accross between the Terminals on the board. If there is no voltage, replace Main control board. If voltage is present, see below.
	Door Switch (switch is located behind magnetic door plate, could be left or right of steamer based on how the unit is hinged).	Perform following test: Unplug unit. Reattached Orange wire to #J7-2. Using a jumper wire - connect Terminal #J7-1 to the common on the pressure switch. Resupply power to unit If starts to heat - replace door switch.
	Solid State Relay	Check for 24-30 VAC on pins A1 & A2 of each Solid State Relay. (Green LED should be lit.) Ensure that Relay Contacts are closing when receiving the 24-30 VAC from the Control/Keypad Board. Check that proper line voltage is being passed through the Solid State Relay to the Heating Elements.
	Contactor	Check that the Contactor is not open, preventing the line voltage to the Solid State Relay(s)
	Cast Heater	Check that the correct Amps (based on KiloWatts of unit) are being drawn from each Element. Ensure that all the required voltages (based on required phase needs of the unit) are present to each Element.

FIG 3.1H

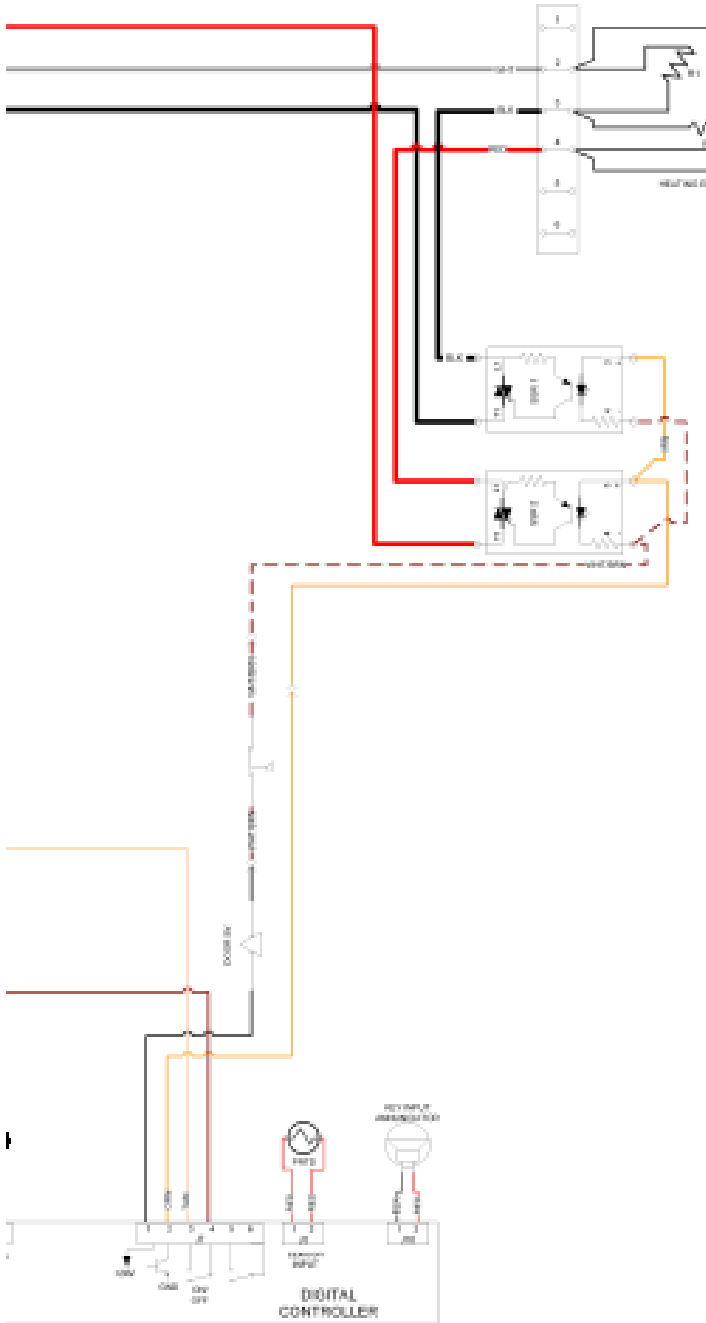

REF LETTER	POSSIBLE CAUSE	TROUBLESHOOTING STEPS
L	Steam Vent Blocked - See Section 4.8	<p>Steam should be coming out of vent at back of steamer.</p> <p>Check for blockage in the vent, which can cause the Chamber Pressure Switch to <u>open</u>.</p> <p>If a blockage is present, try to pour some hot water down the vent piping to unclog the blockage (may have to blow out the blockage if water doesn't help).</p> <p>If the steamer operates with the door cracked but not with it shut, the vent is definitely blocked.</p> <p>Ensure that there is at least a minimum of 1/4" slope for every foot added, of extended exhaust piping.</p> <p>Ensure that any extended exhaust piping is made of stainless steel, or copper; and a minimum of 3/4" in diameter.</p>
	Steam Temperature is Not at Desired Cook Temp	<p>Check that the Door is closed and no steam is escaping from it.</p> <p>Verify that Low Water indicator light is <u>NOT</u> lit.</p> <p>Check that steamer is in the COOK mode and NOT in the HOLD mode.</p>
M	Door Assembly	<p>Check to see if the Door is seating completely around the face of the Steamer.</p> <p>Check that the Door Gasket does <u>NOT</u> have any cuts, nicks, debris, or discolorations (<i>white or grey</i>).</p> <p>Perform a 'dollar bill test.' Trap a dollar bill between the closed door and frame of the unit. There should be significant resistance when attempting to pull the dollar free. Little or no resistance indicates a poor seal. The fit of the door can be adjusted:</p> <ol style="list-style-type: none"> 1. Remove hinge covers. 2. Loosen 6 screws holding hinge to unit. 3. Apply pressure door to attain better fit 4. Retighten screws.
	Pressure Switch	<p>Check that the Chamber Pressure Switch opens and closes.</p> <p>Checking the Ohms reading while blowing into its input hose. (<i>Disconnect the hose from the chamber inlet hole.</i>)</p>
	Steam Vent Blocked	See L

REF LETTER	POSSIBLE CAUSE	TROUBLESHOOTING STEPS
N	Food Cook Time Too Long	<p>Refer to L to ensure unit is cycling heat correctly. Ensure that the proper Cook Time is being used.</p> <p>Refer to the Installation/Operator Manual for cooking tips if no mechanical reason is found for this symptom.</p>
O	Food Cook Time <u>Not</u> Long Enough	<p>Ensure that the steamer is in the COOK mode and <u>not</u> the HOLD mode. (HOLD <i>has a preset temp value that is below that of 212°F.</i>)</p> <p>Check that proper pan placement is being utilized for best cooking conditions. (See <i>Owners Manual</i>)</p> <p>Ensure that the Drain Ball-Valve is shut tightly or possible loss of heating efficiency.</p> <p>Refer to the Installation/Operator Manual for cooking tips if no mechanical reason is found for this symptom.</p>

3.2 TROUBLESHOOTING NOTES

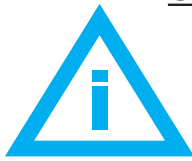

TROUBLESHOOTING NOTES

If the steamer is not reaching temperature:

- Ensure that the steamer is not in the HOLD Mode versus the COOK Mode. The default mode for the steamer, when the PWR button is turned ON, is COOK. So, if the operator presses the Timer Button then the Cook/Hold button; the operator has just placed the steamer in the HOLD Mode and the steamer will not reach 212°F (COOK Mode).
- Ensure that the steam vent (located on the back of the steamer) is not blocked or clogged. If the customer has added an extended exhaust pipe, there's an increased chance of vent blockage, if the exhaust pipe is not installed properly. The exhaust pipe should be made of copper, brass or stainless steel. The exhaust pipe should have a diameter of 3/4"; and be sloped 1/4" for every 12" of length. Also, the addition of extra fittings that can alter the gravitational flow of the steam condensation, can cause blockage. If vent blockage does occur, it will cause the chamber pressure switch to stay open; which prevents the heater from turning back on; and the temperature will continue to drop. Blocked vent can additionally cause steam to blow out of the door.

Auto-Fill Steamer: If the steamer is overfilling with water and causing the steamer to shut-off:

- Ensure the steamer is level, front to back and side to side. An un-level steamer can cause the water in the steam chamber to collect in the front of the steamer, causing the Over-Fill Float Ball to raise and trip the Reed Switch prematurely (every time the steamer is turned ON). Once the Reed Switch trips, it will cause an Over-Fill Light and Buzzer; while turning off the steamer and preventing its usage.
- Ensure that both of the Water Sensors are clean. Build-up of scale or crud will prevent the Water Sensors from providing the appropriate control signals to the Auto-Fill Valve, causing it to overfill with water.
- Ensure that the water pressure being supplied to the Auto-Fill Valve should not be greater than 60 psi. If water pressure is too high, then a larger volume of water will be added to the steam chamber during the auto-fill cycle; causing the steamer to overfill with water.

3.3 MODIFYING CONTROL / KEYPAD PROGRAM SETTINGS

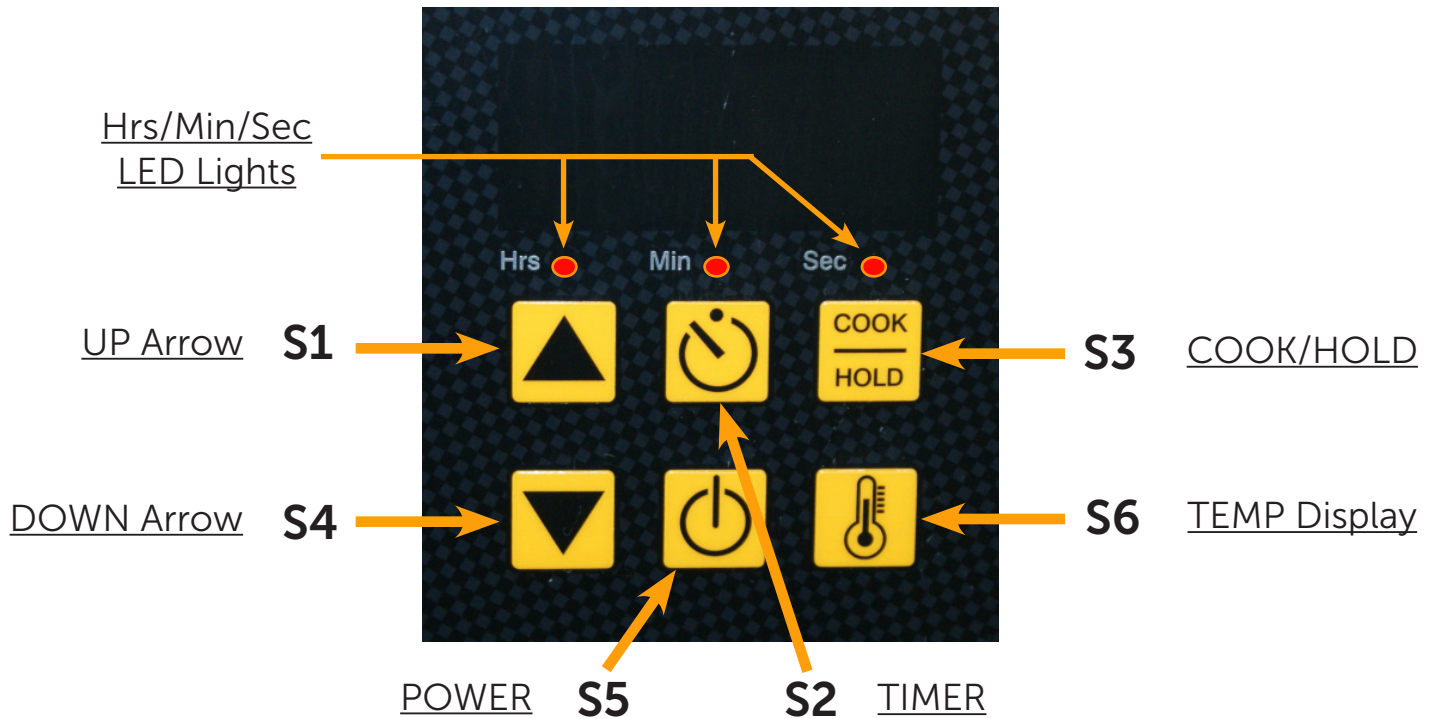

ENTERING PROGRAM MODE: Simultaneously, depress and hold **S4** & **S6** for minimum of **8 seconds** or until the **Hrs LED** blinks and the display shows a Hold Temp number (default is 180°F). Now the Controller can operate under the Program Function Parameters.

- S1 - Increase Program Item (Will cycle the Hrs/Min/Sec LED light)
- S4 - Decrease Program Item (Will cycle the Hrs/Min/Sec LED light)
- S3 - Increase Program Value (Will change the Digital Readout display)
- S6 - Decrease Program Value (Will change the Digital Readout display)
- S2 - Exit & Save**

Program Mode Function Parameter Table

			Change PROGRAM Using Up/Down Arrows	Change PROGRAM Settings using Cook/Hold and Temp display buttons		
Hrs LED	Min LED	Sec LED	PROGRAM	MIN	MAX	ELC
Blink	OFF	OFF	HOLD Temp Value = Degree F	MIN Temp	MAX Temp	180
ON	OFF	OFF	Default Timer Value = Hours	0	8	0
OFF	ON	OFF	Default Timer Value = Minutes	0	59	30
OFF	OFF	ON	TEMP Probe Offset = Degree F	0	50	0
ON	ON	ON	TEMP Probe Offset = Neg/Pos Diff	NEG = 1	POS = 0	0
Blink	Blink	Blink	Hysteresis	2	10	2
ON	Blink	Blink	TEMP Regulating Mode	On/Off = 0	PID = 1	1
Blink	ON	Blink	Proportioning BAND TIME	4	10	10
Blink	Blink	ON	Proportioning BAND WIDTH	4	10	10

PROGRAMMING EXAMPLE

To adjust the HOLD temperature on the steamer - use the following instructions:

1. Depress S4 (down arrow) & S6 (Temp display) buttons at the same time and hold for eight seconds.
2. After 8 seconds, the Hrs LED light will blink and 180F will appear on the display. Release S4 and S6.
3. Press the S3 (cook/hold) or S6 (TEMP display) to alter the HOLD temp.
4. Press S2 to save the input

To adjust the TIMER on the steamer - use the following instructions:

1. Depress S4 (down arrow) & S6 (Temp display) buttons at the same time and hold for eight seconds.
2. After 8 seconds, the Hrs LED light will blink and 180F will appear on the display. Release S4 and S6.
3. Press S1 (up arrow) once to access 'default timer value = hours'. Press either S3 (cook/hold) or S6 (temp display) to increase or decrease the number of hours.
4. Press S1 again to access 'default timer value = minutes'. Press either S3 (cook/hold) or S6 (temp display) to increase or decrease the number of minutes.
5. Press S2 to save the input.

To exit without saving push S5 (power).

3.5 LOCATION OF ELECTRICAL COMPONENTS

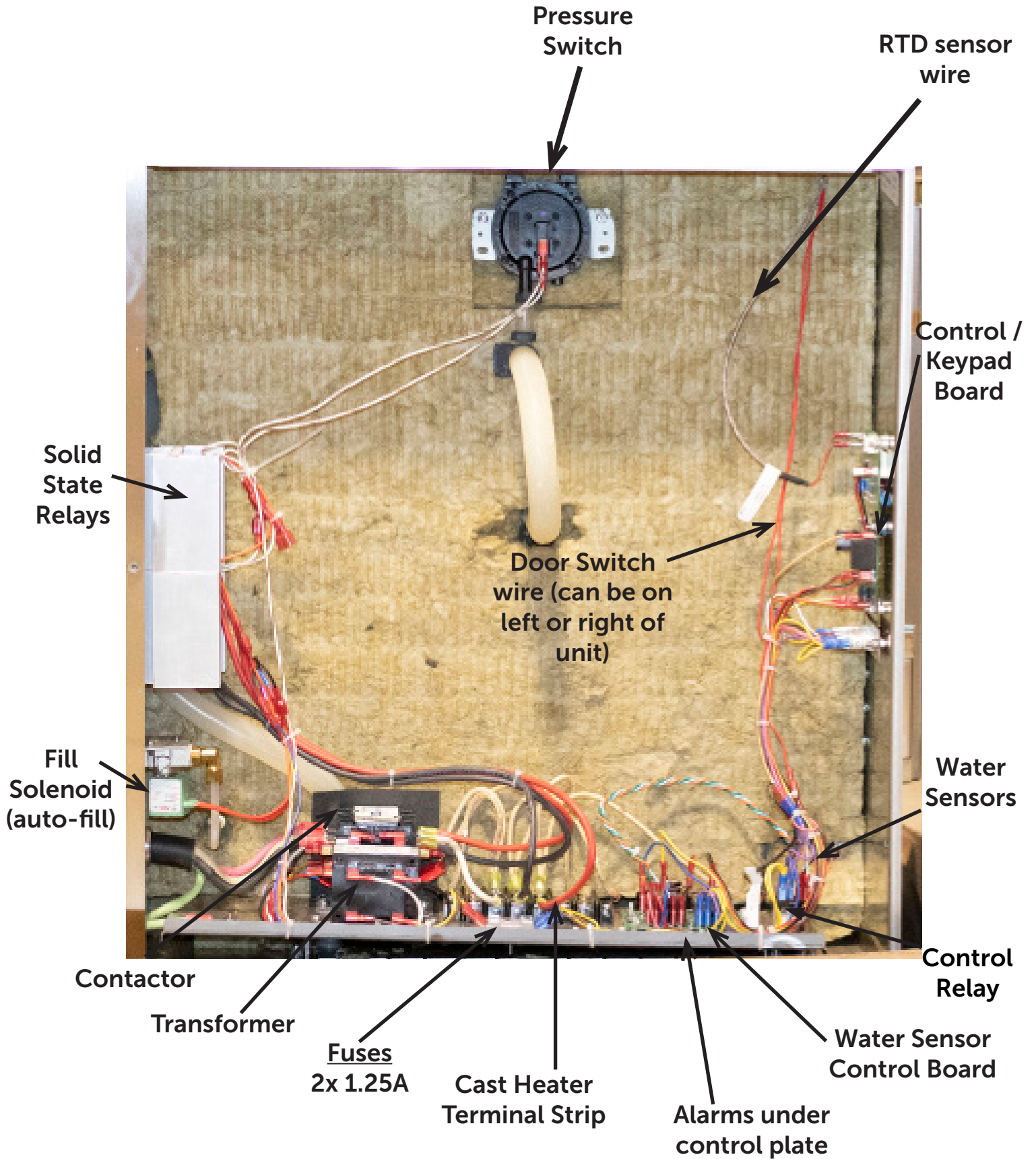

3.6 RECOMMENDED TOOLS

1. Multimeter capable of reading:
VDC & VAC
DC μ A
 Ω & k Ω

2. Digital Clamp Meter
3. Phillips Screwdriver



4. Flat Screwdriver

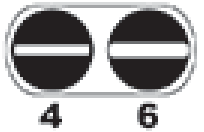

5. Torque Wrench with Imperial socket set
6. Manometer capable of reading Inches Water Column

4.0 Removal and Replacement of Components

4.1 Removal and Replacement of Supply Power Components

CORD & PLUG ASSEMBLY

1. Unplug the Unit.
2. Remove the Left-Side Panel by removing the Sheet Metal Screws holding it in place.
3.
 - A. SINGLE PHASE
Disconnect the Power Cord Leads Black, White from the primary side of the contactor and disconnect the ground wire (green) from chassis.
 - B. THREE PHASE
Disconnect the Power Cord Leads Black, White and Red from the primary side of the contactor and disconnect the ground wire (green) from chassis.
4. On the inside of the unit, remove the retaining nut on the threads of the Power Cord Cable Fitting & pullout the Power Cord.
5. **Re-install in reverse order.**

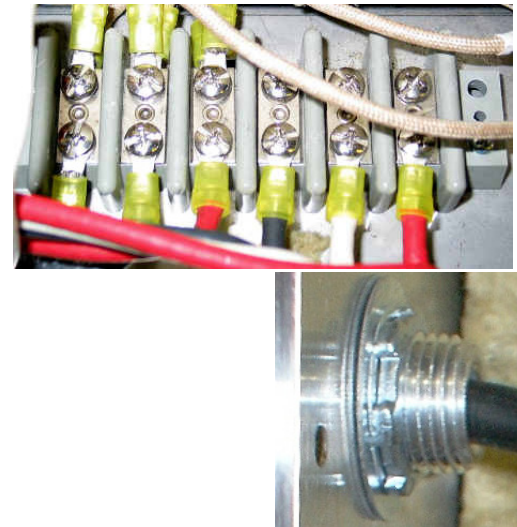

FIG 4.1A

FUSE

1. Unplug the Unit.
2. Remove the Left-Side Panel by removing the Sheet Metal Screws holding it in place.
3. Pry the Fuse(s) out of the Fuse Block with a flat-head screwdriver or fuse puller.
2 x 1.25A
4. **Re-install in reverse order.**

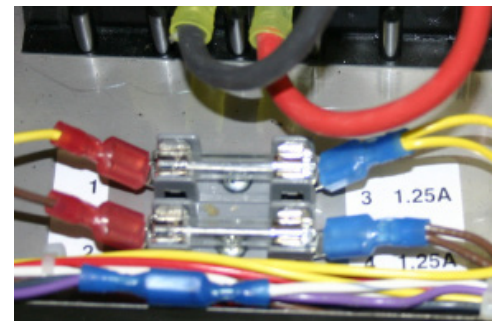
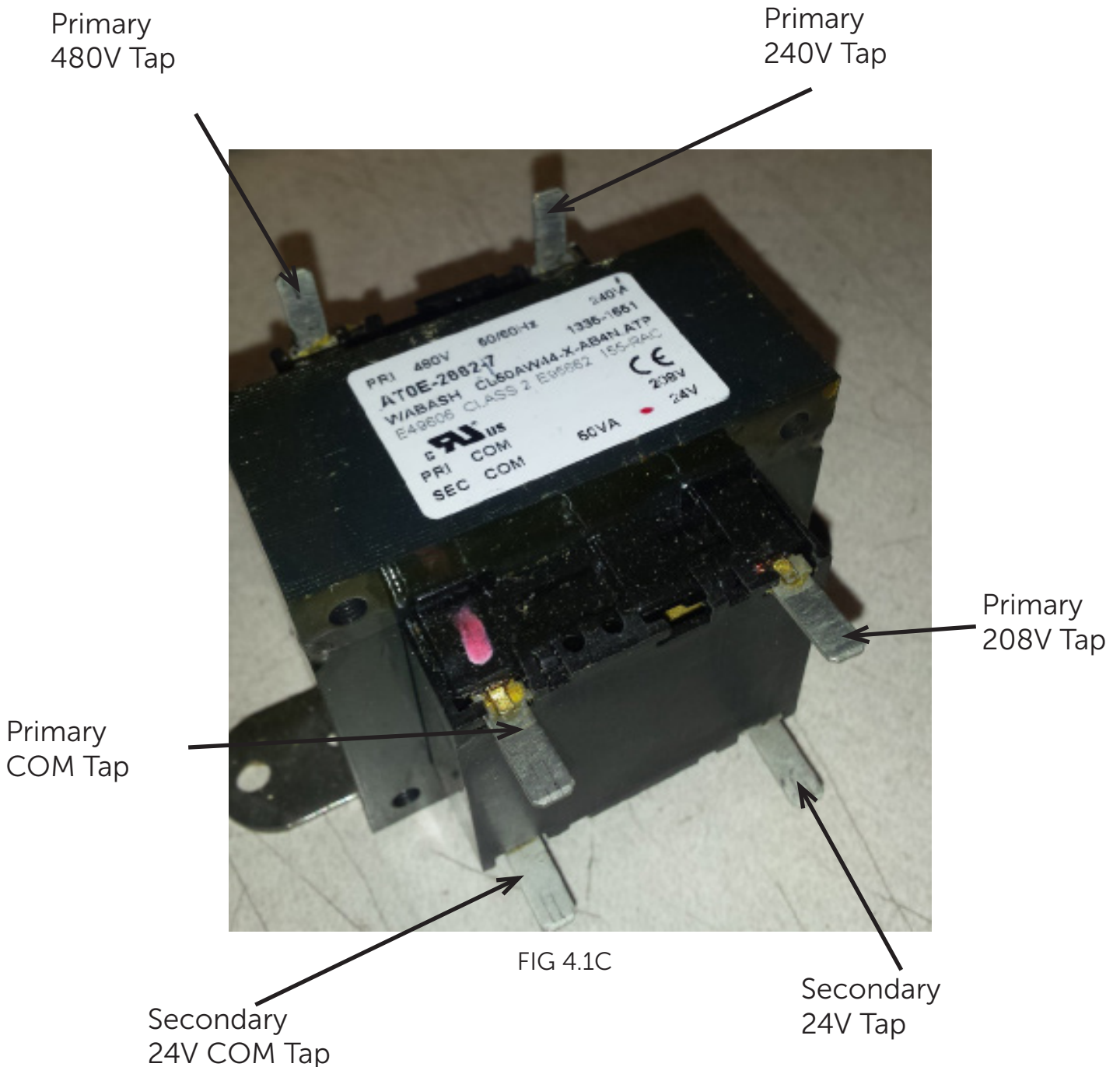

FIG 4.1B

TRANSFORMER

1. Unplug the Unit.
2. Remove the Left-Side Panel by removing the Sheet Metal Screws holding it in place.
3. Disconnect the wires (note the wire color to its location terminal).
4. Remove the 2 mounting nuts and then remove the Transformer (FIG 4.1C).
5. **Re-install in reverse order.**



4.2 Removal and Replacement of Water Level Control Components

WATER SENSOR CONTROL BOARD

1. Unplug the Unit.
2. Remove the Left-Side Panel by removing the Sheet Metal Screws holding it in place.
3. Disconnect the wires (note the wire color to its location pin).
4. **Carefully**, push in the locking leg on the 4 plastic posts while pulling the Water Board up off the posts (note the board's orientation).
5. Remove the Water Board.
6. Remove Plastic legs - these should also be replaced.
7. Re-install in reverse order.



FIG 4.2A



**Do not remove board from the anti static bag until ready to use.
A grounding strap is recommended to remove static**

AUTO-FILL VALVE

1. Unplug the Unit & drain any remaining water from the steam chamber.
2. Close the supply water valve and disconnect the Supply Water Hose coming into the steamer.
3. Remove the Left-Side Panel by removing the Sheet Metal Screws holding it in place.
4. Disconnect the wires from the Auto-Fill Valve (*note the wire color to its location pin*).
5. Disconnect the Auto-Fill Valve Hose Fitting (FIG 4.2B)
6. On the back of the steamer, remove the 4 mounting screws securing the Auto-Fill Valve bracket on the inside of the steamer.
7. Remove the Auto-Fill Valve.
8. **Re-install in reverse order. Ensure Sealant is re-applied to all pipe threading.**

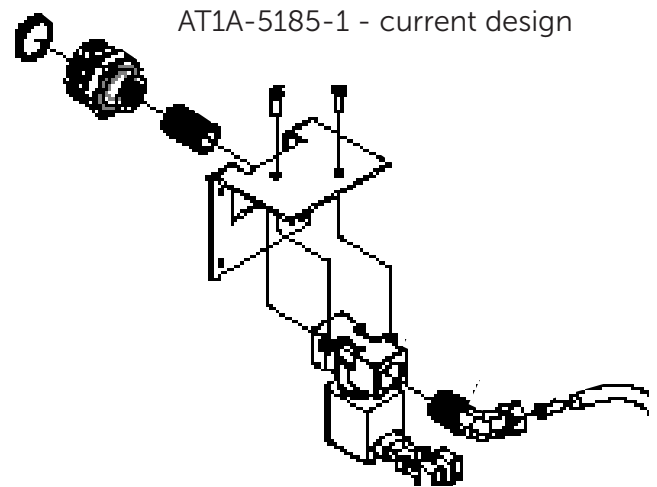
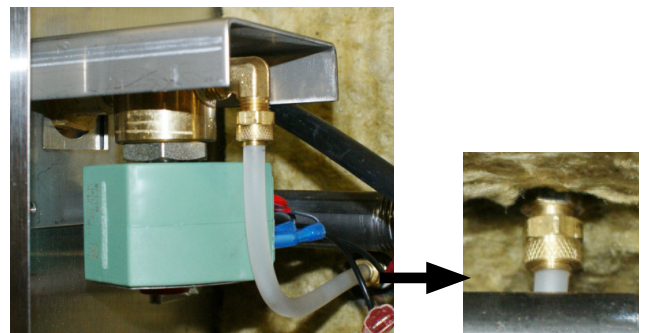

FIG 4.2B



AT1A-5192-1 - Previous design

WATER SENSORS

1. Unplug the Unit.
2. Remove the Left-Side Panel by removing the Sheet Metal Screws holding it in place.
3. Open the door and ensure that all the water is drained from the steam chamber.
4. Disconnect the wire from the backside of the Water Sensor (access via left-side panel).
5. Remove the retaining nut that mounts the Water Sensor to the Steam Chamber.
6. Push the Water Sensor through the hole in the steam chamber from the backside.
7. **Re-install in reverse order. Torque Sensor Nuts to between 12-15 In-Lbs.**



FIG 4.2C

CONTROL RELAYS

1. Unplug the Unit.
2. Remove the Left-Side Panel by removing the Sheet Metal Screws holding it in place.
3. Disconnect the wires (note the wire color to its location pin).
4. Remove the 2 mounting screws and then remove the correct voltage type Control Relay.
5. **Re-install in reverse order.**

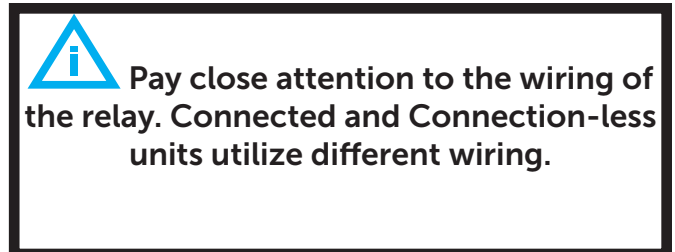
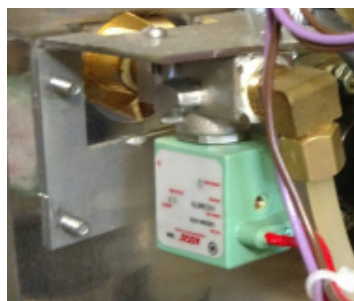

FIG 4.2D



AT1A-5185-1

OVER-FILL REED SWITCH (Auto-fill only)

1. Unplug Unit & close the supply water valve.
2. Disconnect the garden hose from the back of the steamer & drain any remaining water from the steam chamber.
3. Remove the Left-Side Panel by removing the Sheet Metal Screws holding it in place.
4. Disconnect the REED Switch wires (*note the wire color to its location pin*).
5. Turn the unit upside-down and remove its legs. (*Unbolt from stand and then turn unit upside-down if applicable.*)
6. Remove Bottom Cover by removing the Sheet Metal Screws holding it in place. (*Remove Drain Pan Rails if applicable.*)
7. Remove the front, insulation pieces that are laying on-top of the Over-Fill Reed Switch. (*Wire is ran in-between the insulation pieces.*)
8. Remove the retaining nut and lock washer holding the Reed Switch inside the Sensor Post.
9. Remove the High Water Reed Switch (FIG 4.2E).
- 10. Re-install in reverse order.**

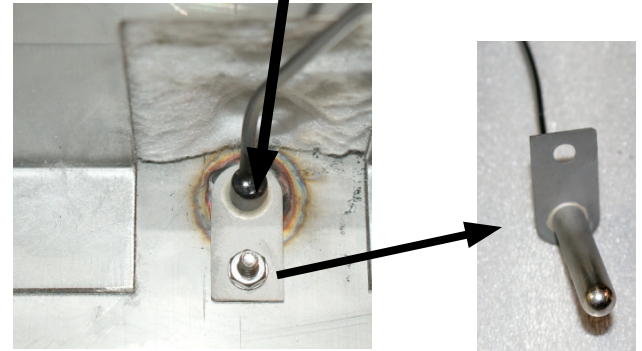
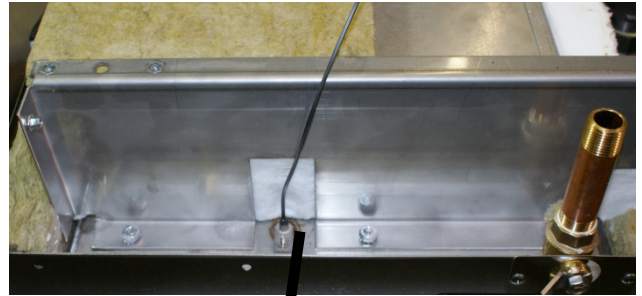

FIG 4.2E



Make sure to route wire through insulation to avoid heat damage to the wires



FIG 4.2F



Handle the float ball carefully as dropping can damage it.

MAGNETIC FLOAT BALL (Auto-fill only)

1. Open the steamer door and remove the left-side pan rail.
2. Lift and remove the steam collection cover plate.
3. Remove the Float Ball off of the High Water Reed Switch Sensor Post.
- 4. Re-install in reverse order. Ensure Sensor Post & Float Ball hole are clean before re-installing.**

DRAIN VALVE

1. Unplug the Unit.
2. Once any water inside the cooking chamber is cool, drain it from the chamber.
3. Verify that the drain valve is cool before proceeding with repair.
4. Turn the unit upside-down and remove its legs. (*Unbolt from stand and then turn unit upside-down if applicable.*)
5. Remove Bottom Cover by removing the Sheet Metal Screws holding it in place. (*Remove Drain Pan Rails if applicable.*)
6. Remove the Drain Handle Cover Plate, and the insulation surrounding the Drain Valve.
7. Remove the Drain Pipe from the Drain Valve.
8. Remove the Drain Valve.
9. **Re-install in reverse order. Ensure Sealant is re-applied to all pipe threading.**

FIG 4.2G

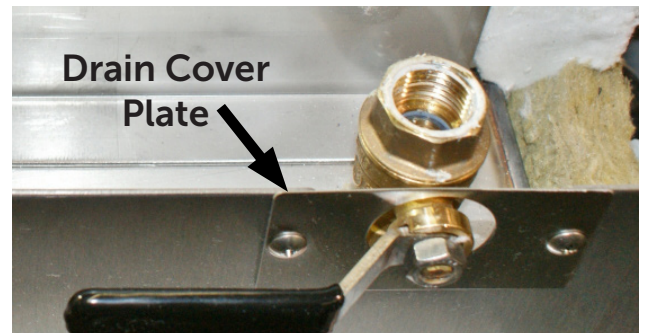
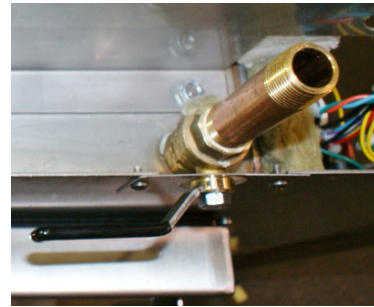

DRIP EDGE

1. Unplug the Unit.
2. Remove the 4 Sheet Metal Screws at the bottom of the Front Panel.
3. Slide the Drip Pan(s) out from between the Front Panel and the Bottom Panel. (*Ensure the split Drip Pans are sloped towards the center of the steamer.*)
4. **Re-install in reverse order.**

Split Drip Edge



FIG 4.2H

CONDENSATE TRAY

1. Power Unit off and allow to cool
2. Wipe condensate tray out with a cloth.
3. Pull Condensate tray out from pan rails.
4. **Re-install in reverse order.**

4.3 Removal and Replacement of Heat Control Components

MAIN CONTROL BOARD

1. Unplug the Unit.
2. Remove the Left-Side Panel by removing the Sheet Metal Screws holding it in place.
3. Disconnect the wires (note the wire color to its location terminal).
4. Remove the 7 mounting nuts and then remove the Control Panel CCA.
5. (If accessing the Program Mode is needed, go to **page 10** for more details.)
6. **Re-install in reverse order.**

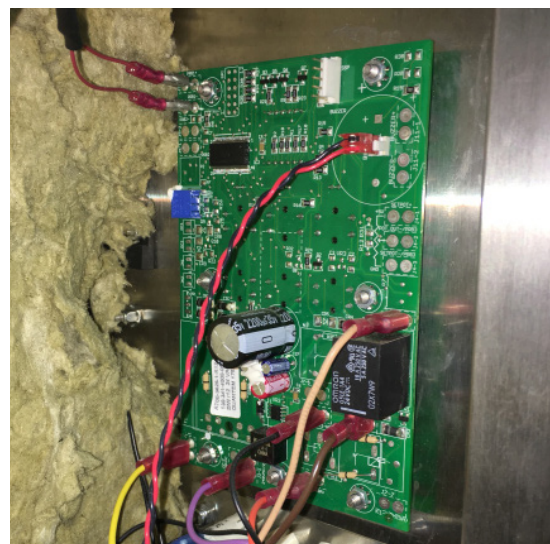

FIG 4.3A

CHAMBER PRESSURE SWITCH

1. Unplug the Unit & remove the Left-Side Panel by removing the Sheet Metal Screws holding it in place.
2. Disconnect the Wiring Terminals from the Chamber Pressure Switch (note the wire color to its location terminal).
3. Remove the hose clamp and disconnect the hose from the Chamber Pressure Switch.
4. Remove the 2 mounting nuts holding the Chamber Pressure Switch to chamber cavity.
5. Remove the Chamber Pressure Switch
6. **Re-install in reverse order.**



FIG 4.3B

ALARM ENUNCIATORS

1. Unplug the Unit.
2. Remove the 4 Sheet Metal Screws at the bottom of the Front Panel.
3. Disconnect wires to enunciator:
 - A. CONTROL BOARD - red and black wires.
 - B. WATER SYSTEM - Blue and Yellow wires
4. Remove the phillips round-head machine screw(s) from the component bracket and lift bracket out.
5. Unscrew Enunciator from component bracket
6. **Reinstall in reverse order.**



FIG 4.3C

Enunciators

Round head machine screw

DOOR SWITCH

FIG 4.3D

Door Latch on the Left-Hand Side

1. Unplug the Unit.
2. Remove the Left-Side Panel by removing the Sheet Metal Screws holding it in place.
3. Disconnect the probe wires: Control/ Keypad Panel J7 Pin 1 & the White/Brown wire from the Chamber Pressure Switch (the wires to the location pins are enter-changeable).
4. Push back the insulation, so you can access the other mounting nut to be removed.
5. Remove the 2 mounting nuts and then remove the Door Switch (4.3D).
6. **Re-install in reverse order.**



The switch features a long length of wire. Use a wire tie to prevent it from being pinched.

Door Latch on the Right-Hand Side

1. Unplug the Unit.
2. Remove the Left-Side, Right-Side, and Top Panel by removing the Sheet Metal Screws holding it in place.
3. Disconnect the probe wires: Control/ Keypad Panel J7 Pin 1 & the White/Brown wire from the Chamber Pressure Switch; and pull the wires up, over the top of the steamer (the wires to the location pins are enter-changeable).
4. Remove the insulation on the right side, to access the Door Switch to be removed (4.3E).

FIG 4.3E



4.4 Cast Heater Removal & Replacement

The following parts are included in the repair kit:

Part Number	Description	QTY
AT1A-3531-X	Cast Heater Assembly (X = based on Voltage and kW rating)	1
AT0H-3412-2	Thermal Joint Compound	1
AT1E-2653-X	OverTemp Switch (X = 3 or 4 based on Kit ordered)	1
AT0F-3401-1	Nut, Special Locking 1/4 -20UNC-2B	25
AT0H-5176-1	Pocket Comb Fine Tooth	1

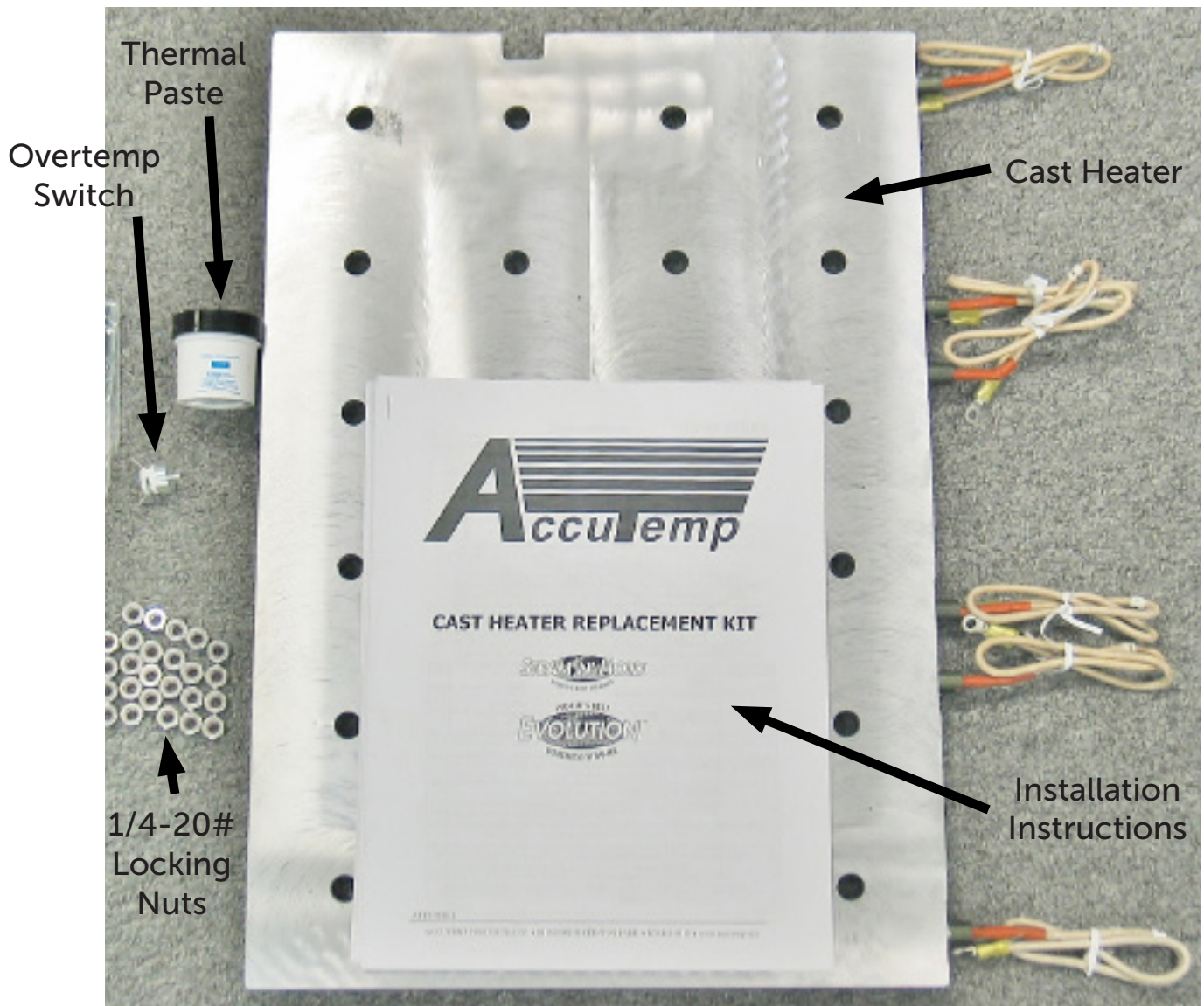

FIG 4.4A



NOTE

An additional person is required when performing this repair.
If the heater wires do not have braided insulation, it is not a cast heater.
Contact AccuTemp Service at 800-480-0415
Use the included instruction booklet in conjunction with this manual to complete the repair.

CAST HEATER

1. Unplug the unit and drain all the water out of the steamer.
2. Remove Left-Side panel by removing the Sheet Metal Screws holding it in place.
3. The cast heater has braided insulation on its lead wires, which run directly to the terminal block. The braided leads are numbered. Make a note of what number lead goes to each position on the terminal, then disconnect the heater lead wires from the terminal block.
4. Using an additional person, turn the unit upside-down and remove its legs. (Unbolt unit from stand and then turn unit upside-down if applicable.)
5. Remove the Bottom Cover by removing the Sheet Metal Screws holding it in place. (Remove Drain Pan Rails if applicable.)
6. Remove insulation as needed to access the Cast Heater. (Note the insulation's location to ensure proper fitting when re-installed.)
7. Disconnect the wires to the Overtemp Switch (note the wire color to its location pin).
8. Unscrew the Overtemp Switch by hand and remove it from the bottom of the Cast Heater (FIG 4.4A).
9. Clean the bottom of the steamer. All heat transfer compound must be removed. When the bottom is clean, check for foreign material or anything else that would cause even a tiny gap between the bottom of the steamer and the heater. Clean it off also.
10. Remove all 24; Locking Nuts (FIG 4.4B), Lock Washers (FIG 4.4C) & Flat Washers (FIG 4.4D) from the Cast Heater. (Discard the used Locking Nuts; keep and clean the Lock & Flat Washers.)
11. Remove both Heater Mounting Brackets (FIG 4.4E) from the top of the heater by letting them hang, by the wires, over the electrical compartment.
12. Remove the Cast Heater. Use a flat-head screwdriver to pry up the Cast Heater from the Thermal Compound.
13. Check the bottom of the steamer with a machinist rule to assure that the bottom is flat in the vertical and horizontal planes.



If Heater Studs are Discovered Broken While Removing the Cast Heater
OR
If a Heater Stud Breaks-Off While Removing or Installing the Cast Heater

Call AccuTemp Service Dept (800) 480-0415.

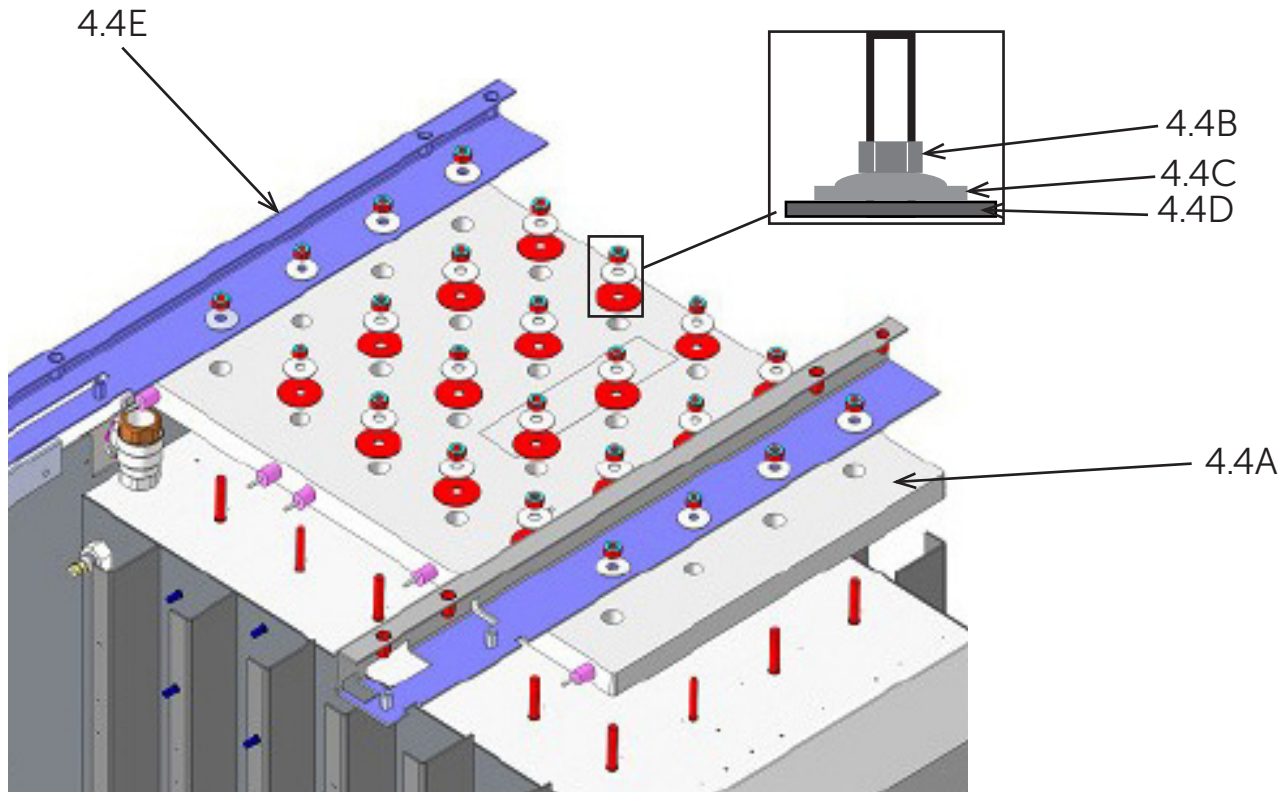

14. Clean the studs so thread locker will adhere to them.
15. Lay the cast heater on a table with the smooth shiny side up. Wipe the surface clean and apply 1.5 - 2.0 ounces of heat transfer compound to the smooth side of the casting using the putty knife. Use the putty knife to spread the thermal compound across the entire surface of the cast heater.
16. When the surface is covered, hold the fine tooth comb (included with the kit) vertical and draw it along the length of the heater in several passes to obtain an even, uniform thickness coating across the entire surface. After each pass, remove excess compound with the putty knife. When finished it should look like an even surface containing fine lines of the compound. If the lines of compound do not cover, add additional compound in those areas and repeat.



Do not pick the heater up by the lead wires. Doing so may damage the connections.

17. Set the heater in place on the steamer with the heat transfer paste in contact with the steamer bottom. The notch in the heater casting should be towards the front of the steamer and the heater wires should be towards the electrical compartment. Try not to get paste on the studs when putting the heater in place. Center the holes in the casting on the studs.
18. Swing the heater mounting brackets back over the heater.
19. Place the large fender washers over the center studs.
20. Place a spring washer over each stud. Spring washers are conical shaped washers that flatten out as the nuts are tightened against them. The spring washers should point up like a miniature volcano. The purpose of the spring washer is to allow the heater to expand and contract with changes in temperature.
21. Install new nuts on the studs and hand tighten. Use an inch pound torque wrench and tighten each nut to 37 inch pounds per the tightening sequence in FIG 4.4F **Do not over-tighten the nuts.** Repeat the tightening procedure with the torque wrench to check that each nut is at 37 inch pounds.

FIG 4.4F

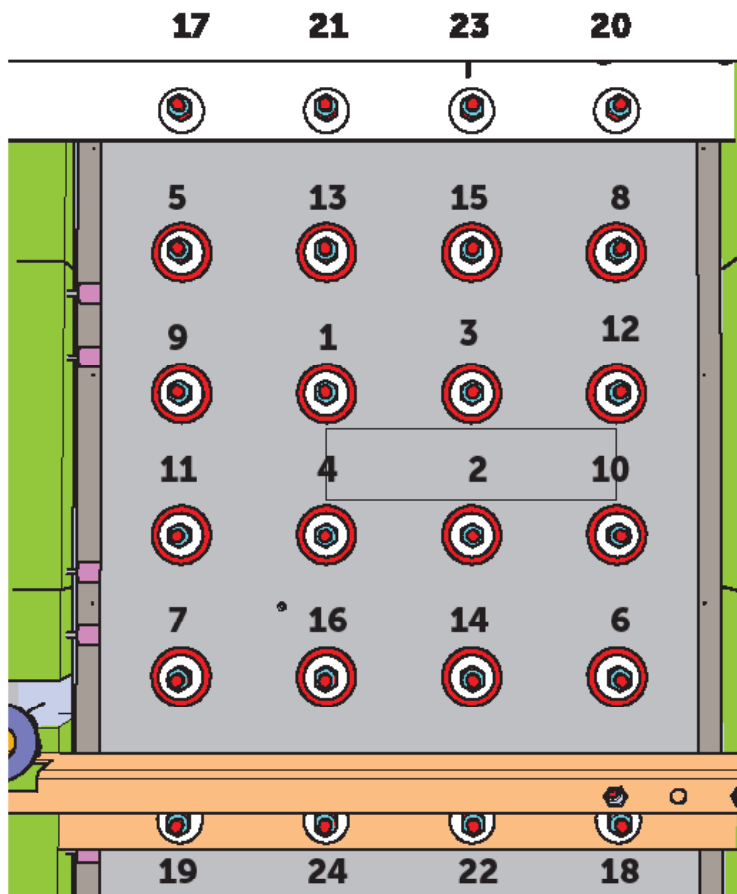



DO NOT OVER TORQUE THE LOCKING NUTS.

Over torquing the nuts can cause the studs to break-off. This Will Cause Heating Issues; and the Steamer Will Not Operate Correctly or Safely.

22. A bead of heat transfer compound should have squeezed out around the entire perimeter of the casting. If it hasn't, not enough paste was applied, or there is something between the steamer and heater preventing good contact. In this case, remove the heater and apply more heat transfer compound.
23. Apply heat transfer compound to the bottom and stud on the high-limit thermostat and screw it in the threaded hole on the rough side of the heater. It should be tight, but only finger tight. **Do not use any tools to tighten it.**
24. Replace the insulation covering the heater
25. Connect the wires to the high-limit thermostat. Push the wires into the slit in the insulation so they don't rub on the bottom cover. Push the thermostat connectors down so they don't rub either.
26. Reassemble the steamer and connect the heater wires to the terminal block in the correct positions.



Additional Notes

- **CAST HEATER'S SHINY SIDE FACES THE BOTTOM OF THE STEAMER**
- **Bellevalle Washers should look like mini-volcanos when placed on heater stud.**
 - **The HEX Locking Nut Needs to be Torqued Between 37 IN-LBS. Tighten Starting with Nut #1 and Follow the Numbered Layout Pattern to Nut #24.**
Tighten Twice in This Pattern.

4.5 Removal and Replacement of Door Assembly

DOOR ASSEMBLY

1. Unplug the unit and shut the Door.
2. Remove the Hinge Covers (FIG 4.5A).
3. Remove the 3 hinge screws going into the face of the steamer of the Bottom Hinge (FIG 4.5B).
4. While supporting the Door on the hinge-side, remove the 3 hinge screws into the face of the steamer of the Top Hinge.
5. Pull the door handle and remove the Door.
6. **Re-install in reverse order. Ensure Anti-seize is re-applied to all hinge screws.**

FIG 4.5A



FIG 4.5B

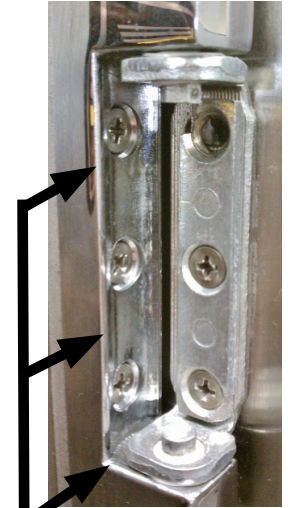

Face Screws

 If the Door Handle Latch Is Moved to the Opposite Side, Ensure That the Door Switch Is Moved to the Corresponding Door Handle Latch Side .
STEAMER WILL NOT OPERATE IF NOT DONE.

INNER-DOOR PANEL

1. Unplug the unit and shut the Door.
2. Remove the Hinge Covers (FIG 4.5A).
3. Remove the very bottom screw on the door hinge-side of the Bottom Hinge.
4. Remove the very top screw on the door hinge-side of the Top Hinge.
5. Slowly open the door as the inner panel may fall when door is opened.
6. Lift and pull out the Inner Door Panel.
7. **Re-install in reverse order. Ensure Anti-seize is re-applied to all hinge screws.**

FIG 4.5C

Inner Door

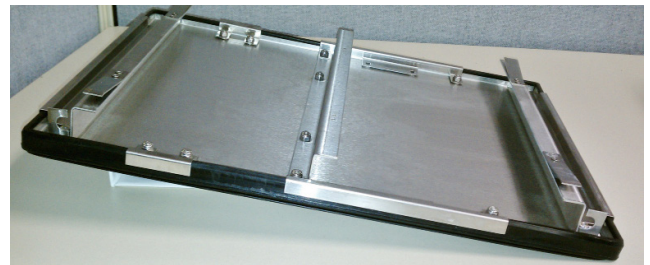

FIG 4.5D

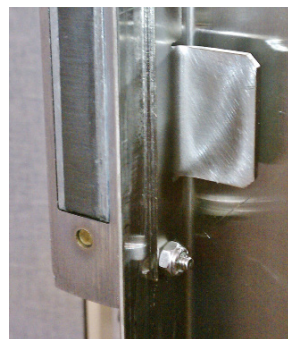



FIG 4.5E



 Ensure That the Inner Door is Reinstalled with its Middle Brace Bar Behind the Door Latch Tab FIG 4.5D
Also, Ensure That the Screw Retainer Openings are Lined-Up with the Door's Hinge Side FIG 4.5E

REVERSING THE DOOR

Should it be desired, the door orientation can be reversed.

1. Unplug the unit and shut the door.
2. Ensure the unit is cool and drained of water.
3. Remove the 3 hinge screws going into the face of the steamer of the Bottom Hinge (FIG 4.5F).
4. While supporting the Door on the hinge-side, remove the 3 hinge screws into the face of the steamer of the Top Hinge.
5. Pull the door handle and remove the Door.
6. Remove the two 3/8th sheet metal screws covering the latch strike plate mounting holes on the hinge side.
7. Remove the six 3/8th screws covering the mounting holes opposite the hinges (FIG 4.5F).
8. Remove the two Phillips Machine screws securing the latch strike plate and shim. Set aside for later use.
9. Replace the eight 3/8th screws in the mounting holes vacated by the hinges and strike plate.
10. Reinstall strike plate and shim in reverse order.
11. Reinstall door in reverse order - the latch handle will now face the opposite direction than previously.
12.  The door switch MUST be relocated to match the orientation of the latch. Follow the instructions in Section 4.3 '[DOOR SWITCH](#)' to transfer the switch



FIG 4.5F

DOOR HANDLE LATCH ASSEMBLY

1. Unplug the unit & shut the Door.
2. Remove the Hinge Covers (FIG 4.5G).
3. Remove the very bottom screw on the door hinge-side of the Bottom Hinge & remove the very top screw on the door-side hinge of the Top Hinge.
4. Pull the door handle and open the door
5. Lift and pull out the Inner Door Panel.
6. Remove the 3 mounting nuts and screws, holding the Door Handle Latch to the side of the door, and the Inner Door Holding Tab.
7. Remove the Door Handle Latch Assembly.
8. **Re-install in reverse order. Ensure Anti-seize is re-applied to all hinge screws.**

DOOR HINGE

1. Unplug the unit & shut the Door.
2. Remove the Hinge Covers (FIG 4.5A).
3. Remove the 3 hinge screws going into the face of the steamer of the Bottom Hinge.
4. While supporting the Door on the hinge-side, remove the 3 hinge screws into the face of the steamer of the Top Hinge.
5. Pull the door handle and remove the Door.
6. Remove the very bottom screw on the door hinge-side of the Bottom Hinge & remove the very top screw on the door-side hinge of the Top Hinge.
7. Lift and pull out the Inner Door Panel.
8. Remove the remaining door-side screws for the hinge or hinges to be replaced.
(Note the orientation of the Hinge Spacer Bars as they relate to the Hinge orientation.)
9. Remove the Door Hinge or Hinges.
10. **Re-install in reverse order. Ensure Anti-seize is re-applied to all hinge screws.**

FIG 4.5G



**Ensure That the Inner Door is Reinstalled with its Middle Brace Bar Behind the Door Latch Tab (FIG 4.5H).
Also, Ensure That the Screw Retainer Openings are Lined-Up with the Door's Hinge Side (FIG 4.5I).**

FIG 4.5H

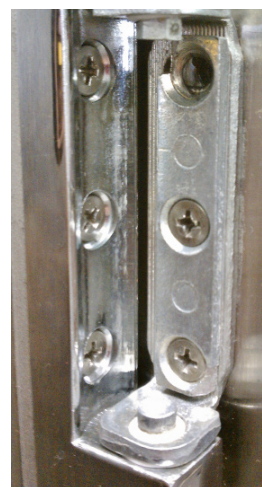
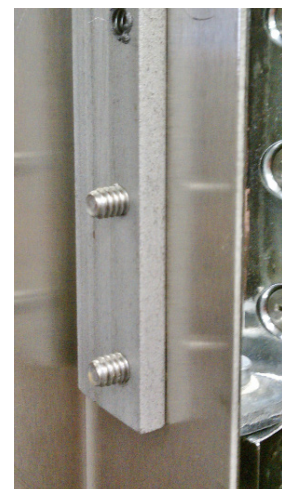

FIG 4.5I



DOOR GASKET

1. Unplug the unit & shut the Door.
2. Remove the Hinge Covers (FIG 4.5A).
3. Remove the very bottom screw on the door hinge-side of the Bottom Hinge & remove the very top screw on the door-side hinge of the Top Hinge.
4. Pull the door handle and open the door
5. Lift and pull out the Inner Door Panel.
6. Remove the 6, Gasket retaining brackets by removing the 12 nyloc mounting nuts holding them in place.
7. Remove the Door Gasket.
8. **Re-install in reverse order. Ensure Anti-seize is re-applied to all hinge screws.**

INSTALLATION NOTE:

- Make sure the new Door Gasket is untangled.
- Starting at one corner, stretch the Gasket to the opposite corner.
- Repeat this sequence until all 4 corners are seated.
- Push the Gasket down all the way around to ensure the Gasket seats firmly on the inner door.



Ensure That the Inner Door is Reinstalled with its Middle Brace Bar Behind the Door Latch Tab FIG 4.5D.

Also, Ensure That the Screw Retainer Openings are Lined-Up with the Door's Hinge Side FIG 4.5E.

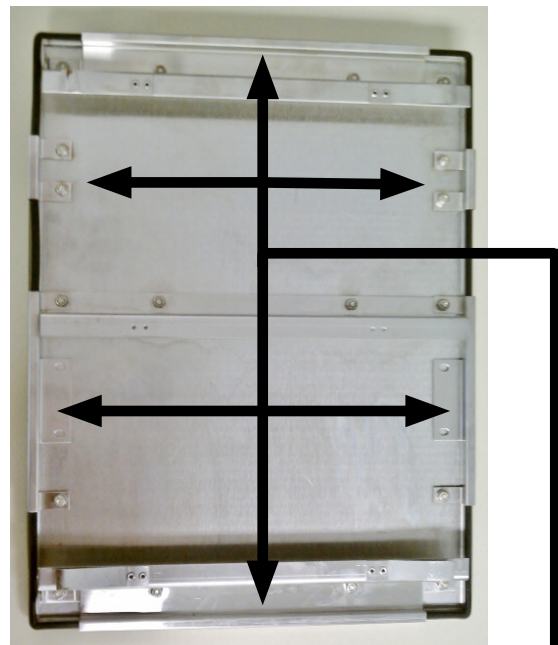

**Gasket Retaining
Brackets**
FIG 4.5J

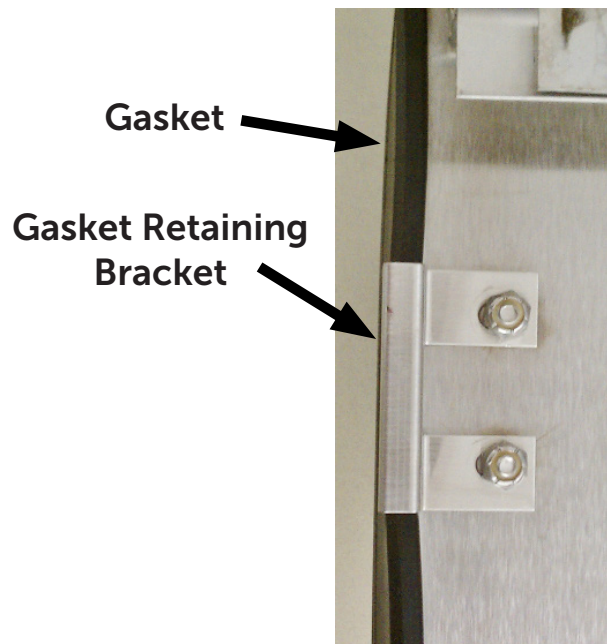

FIG 4.5K

4.6 Removal and Replacement of Temperature Sensors

TEMPERATURE (RTD) SENSOR

FIG 4.6A

1. Unplug the Unit.
2. Remove the Left-Side, Right-Side, and Top Panel by removing the Sheet Metal Screws holding it in place.
3. Disconnect the probe wires from the Control/Keypad Panel and pull them from the left, over the top, to the steamer's right-side (the wires to the location pins are enter-changeable).
4. Remove the mounting nut and then remove the Temperature (RTD) Sensor.
5. Re-install in reverse order. Ensure Thermal Paste is applied to the Temperature (RTD) Sensor.

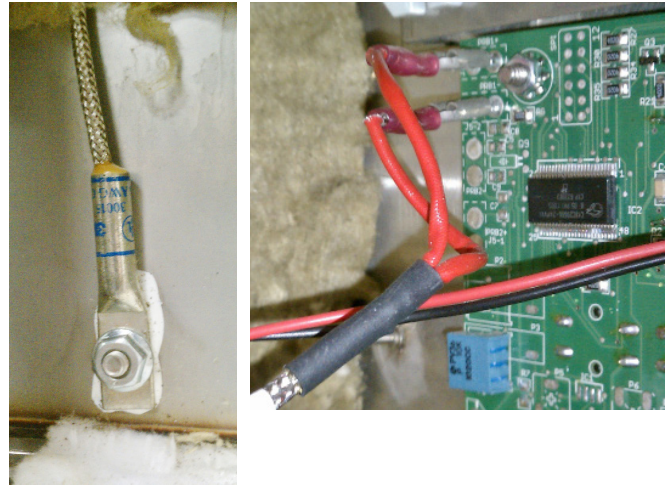

OVERTEMP SWITCH

1. Unplug the unit and drain all the water out of the steamer.
2. Remove Left-Side panel by removing the Sheet Metal Screws holding it in place.
3. Using an additional person, turn the unit upside-down and remove its legs. (Unbolt unit from stand and then turn unit upside-down if applicable.)
4. Remove the Bottom Cover by removing the Sheet Metal Screws holding it in place. (Remove Drain Pan Rails if applicable.)
5. Remove insulation as needed to access the Cast Heater. (Note the insulation's location to ensure proper fitting when re-installed.)
6. Disconnect the wires to the Overtemp Switch (note the wire color to its location pin).
7. Unscrew the Overtemp Switch, and remove it from the bottom of the Cast Heater. Apply heat transfer compound to the bottom and stud on the high-limit thermostat and screw it in the threaded hole on the rough side of the heater. It should be tight, but only finger tight. **Do not use any tools to tighten it.**
8. Replace the insulation covering the heater
9. Connect the wires to the high-limit thermostat. Push the wires into the slit in the insulation so they don't rub on the bottom cover. Push the thermostat connectors down so they don't rub either.
10. Reassemble the steamer and test the unit operation

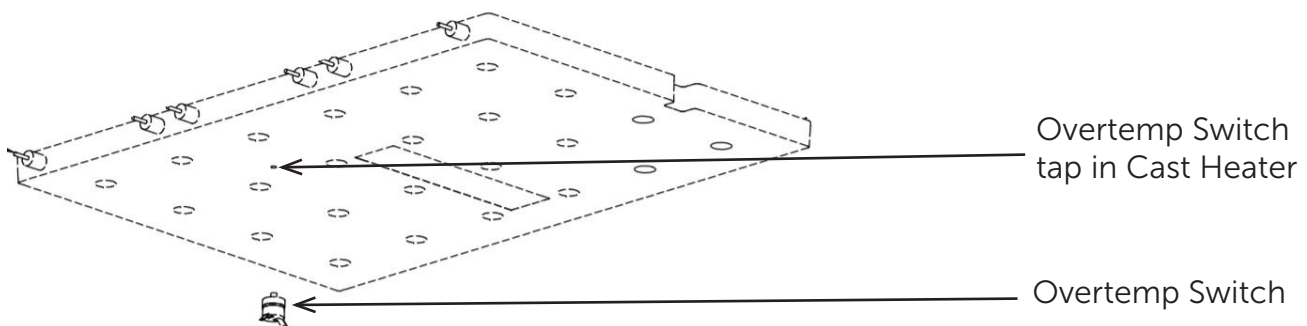

4.7 Steam Vent Components

It may be necessary to have to clean or replace the steam vent components. Also provided are instructions for adding additional vent piping to the exterior of the unit to enable the safe venting of steam.

INTERIOR STEAM VENT - SN 58694 AND BELOW

1. Shut off external breaker to the unit.
2. Remove the Left-Side Panel by removing the Sheet Metal Screws holding it in place.
3. Detach the 1/4 inch silicon hose from the 90° elbow by removing the hose clamp.
4. Remove the 90° elbow from the bullhead T-fitting.
5. Use compressed air to blow out both the 90° elbow and the T-fitting.
6. A brass bore brush can be used to clean the fittings also.
- 7. Reinstall in reverse order.**



FIG 4.7A

INTERIOR STEAM VENT - SN 58695 AND ABOVE

1. Shut off external breaker to the unit.
2. Remove the Left-Side Panel by removing the Sheet Metal Screws holding it in place.
3. Detach the 1/2 inch silicon hose from the bottom of the brass vent assembly by removing the hose clamp.
4. Use compressed air to blow out the vent assembly.
5. A brass bore brush can be used to clean the fittings also.
- 6. Reinstall in reverse order.**



4.7.1 Mounting Vent Extensions sloping upwards

1. Use nominal $\frac{3}{4}$ " copper, brass or stainless steel to prevent flow restrictions. Larger inside diameter (ID) can be used also
2. Pipe should slope upward a $\frac{1}{4}$ " per foot from the steamer vent toward a vent hood to allow water condensing in it to run back to the steamer and down the drain line. Minimum recommended slope is $\frac{1}{4}$ " per foot of hose length.
3. Use rigid pipe rather than flexible tubing or hose to prevent dips or sags in the pipe that may collect water. A puddle of water in the piping just $\frac{1}{2}$ " deep will cause the steamer to malfunction. Recommended pipe materials are rigid $\frac{3}{4}$ " copper tubing ($\frac{7}{8}$ " OD) or brass/ 18-8 stainless steel pipe ($\frac{3}{4}$ NPT or larger). Pipe hangers or pipe supports should be used every six feet to prevent long runs from sagging.
4. A pipe union should be installed next to the steamer to permit the vent to be easily disconnected. This allows the steamer to be easily moved for servicing.
5. Total length of extended vent piping should not exceed 15 feet.

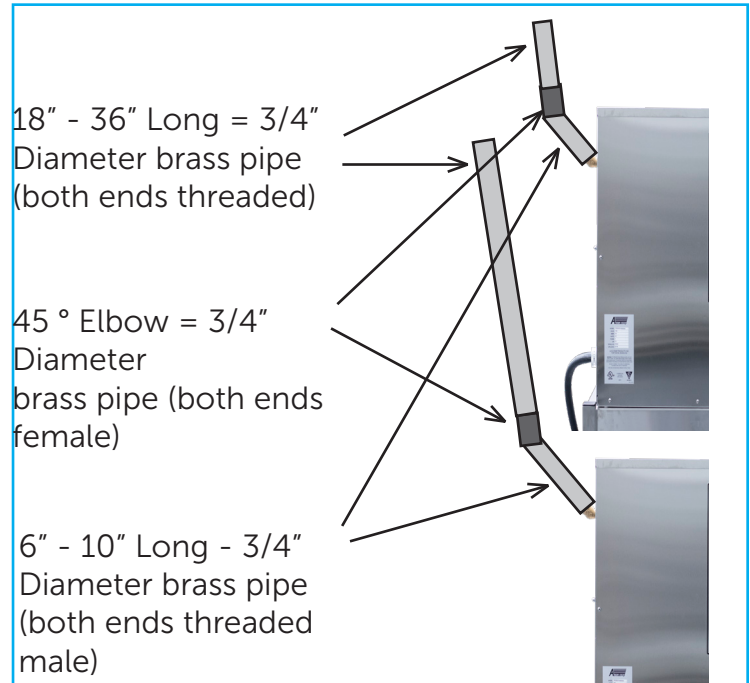
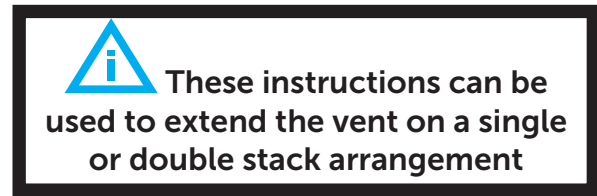

FIG 4.7C

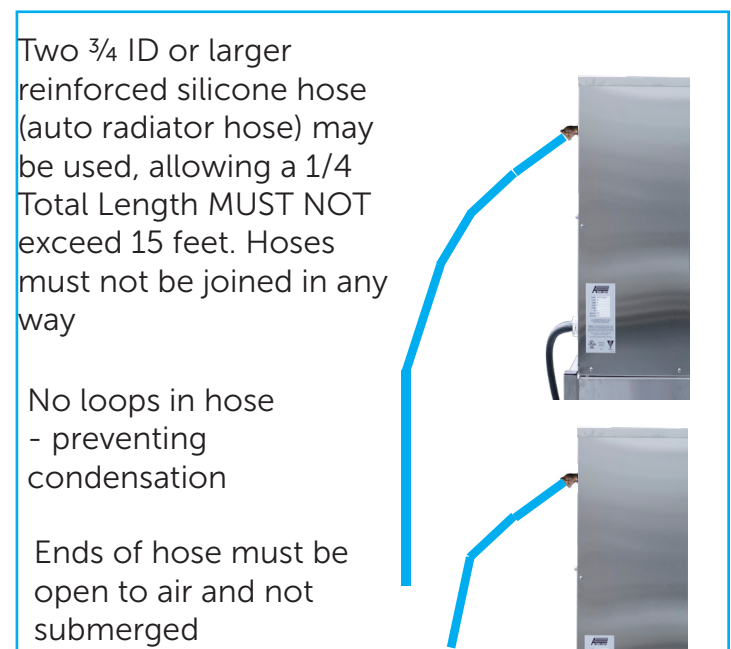
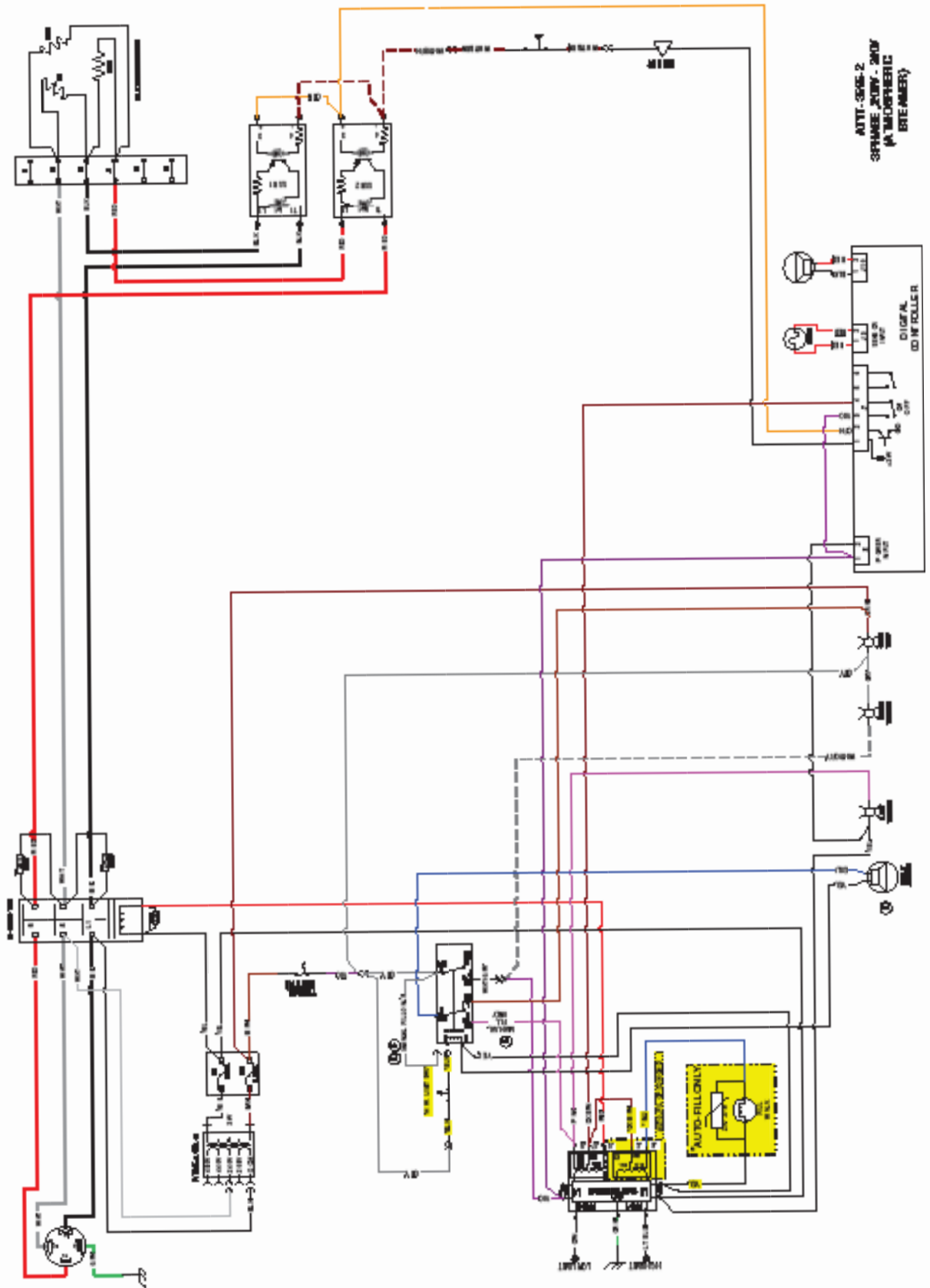

FIG 4.7D

5.0 Wiring Schematics

5.1 Wiring Schematic for SN 36980 and Below

(Further voltage schematics are available - please call 800-480-0415)



5.2 Wiring Schematic for SN 36981 and Above

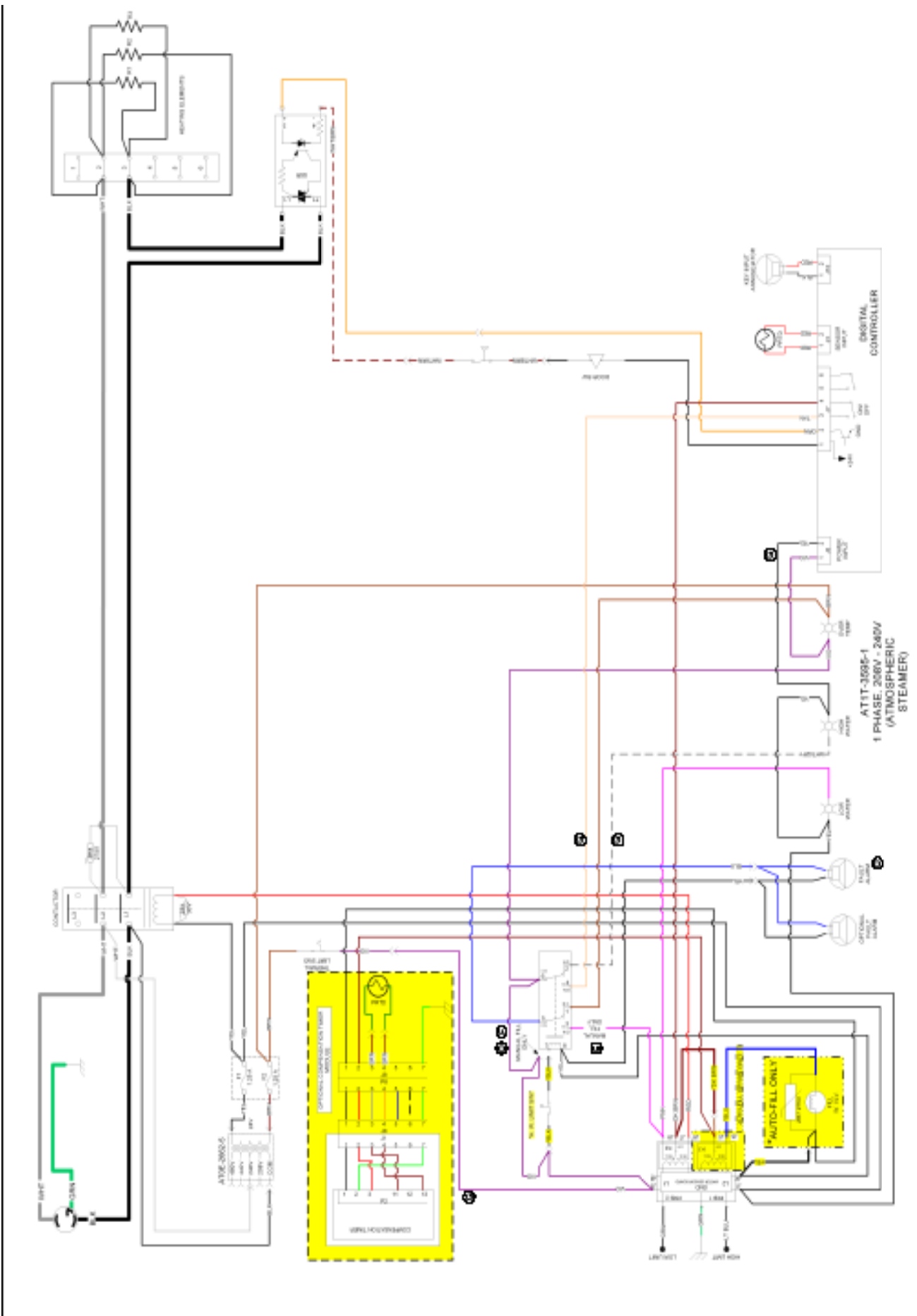

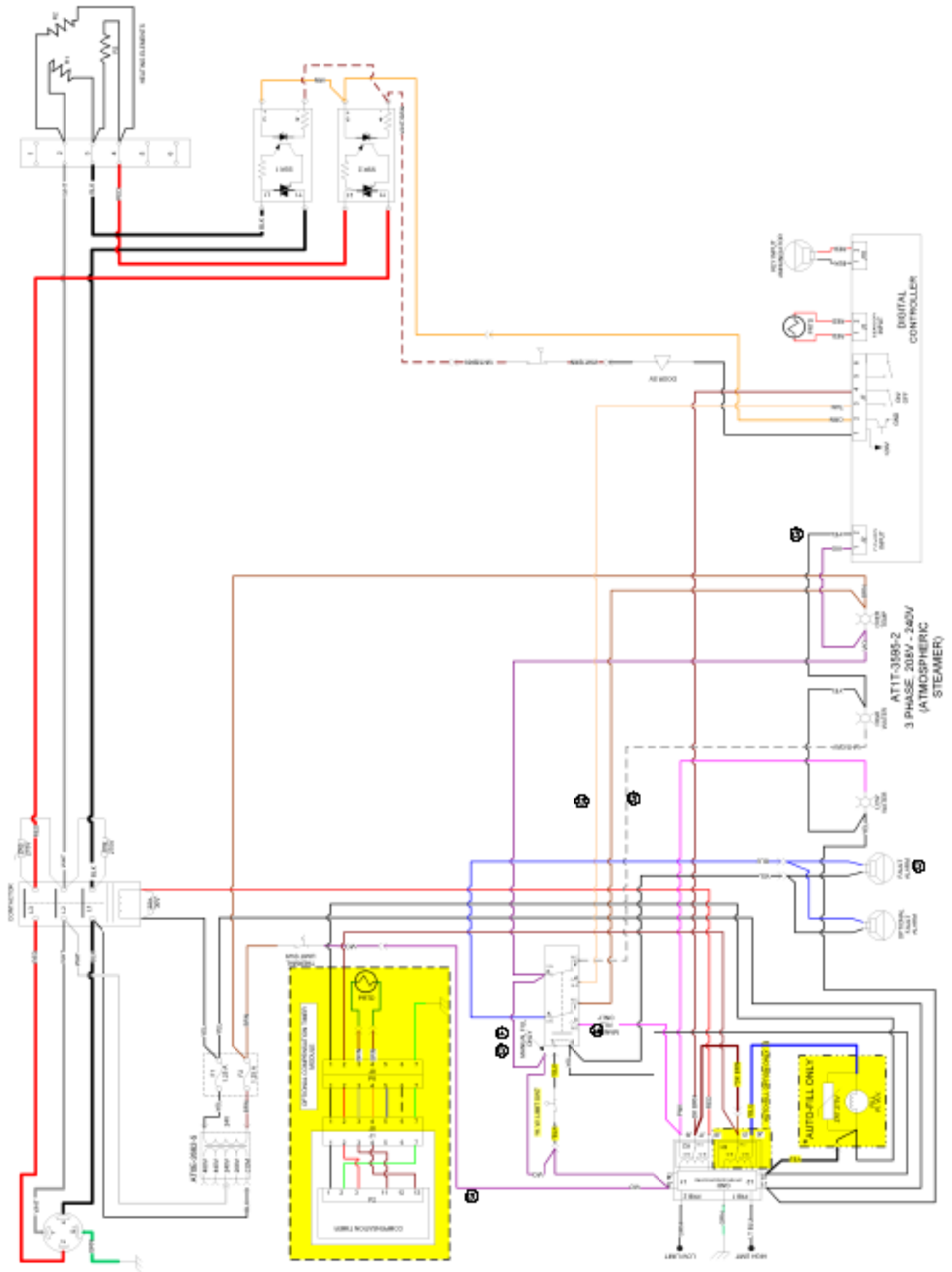

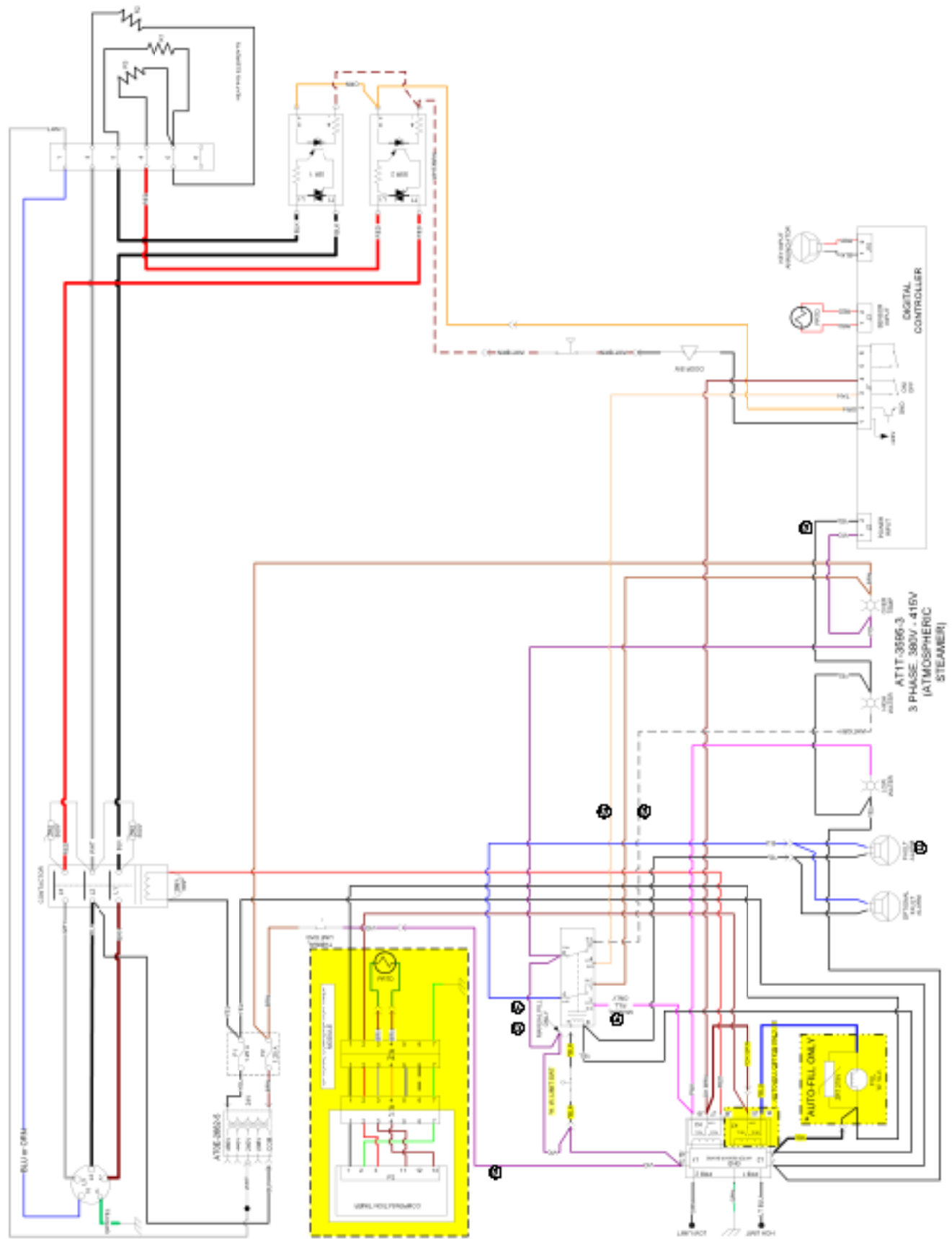

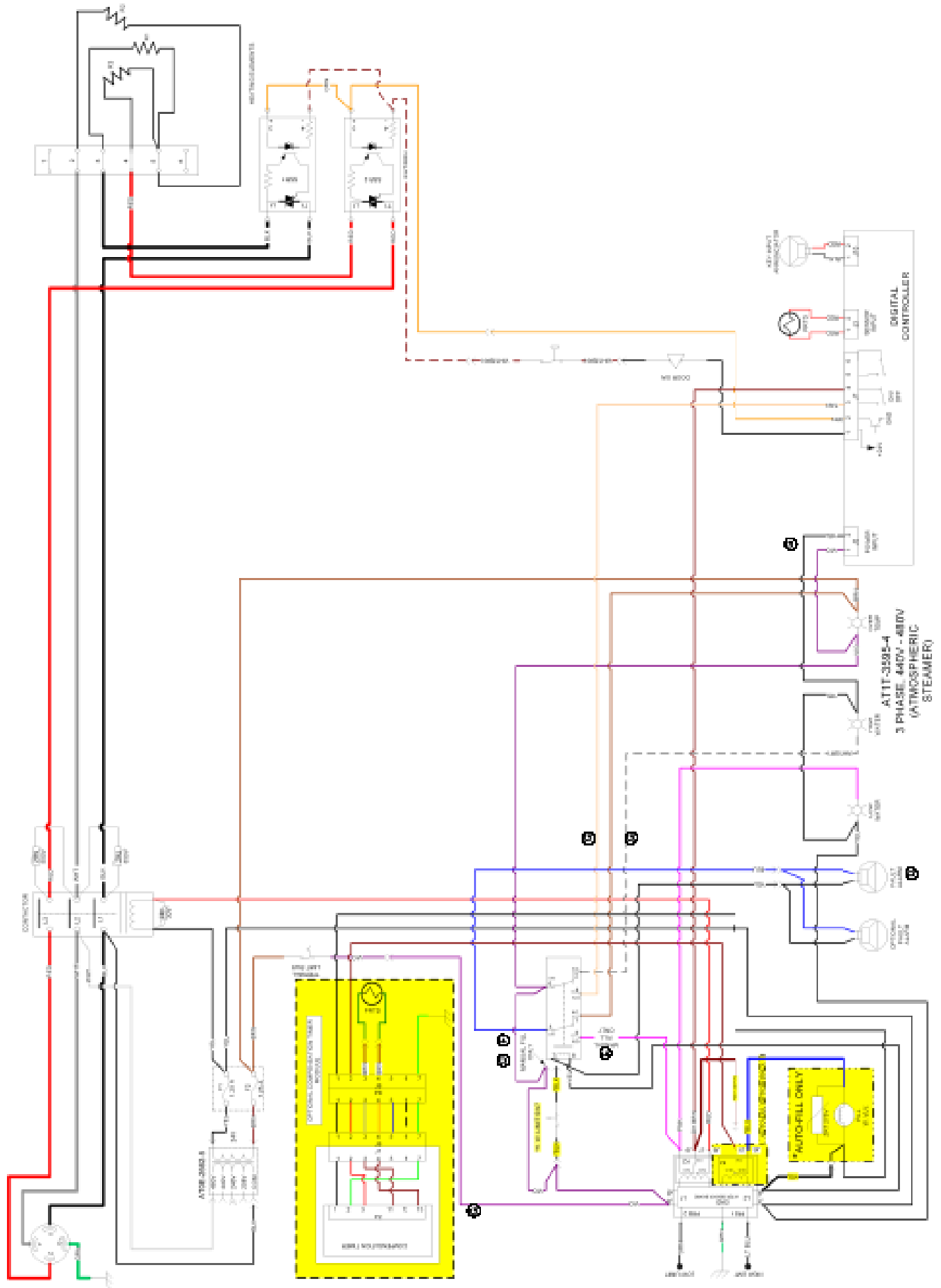

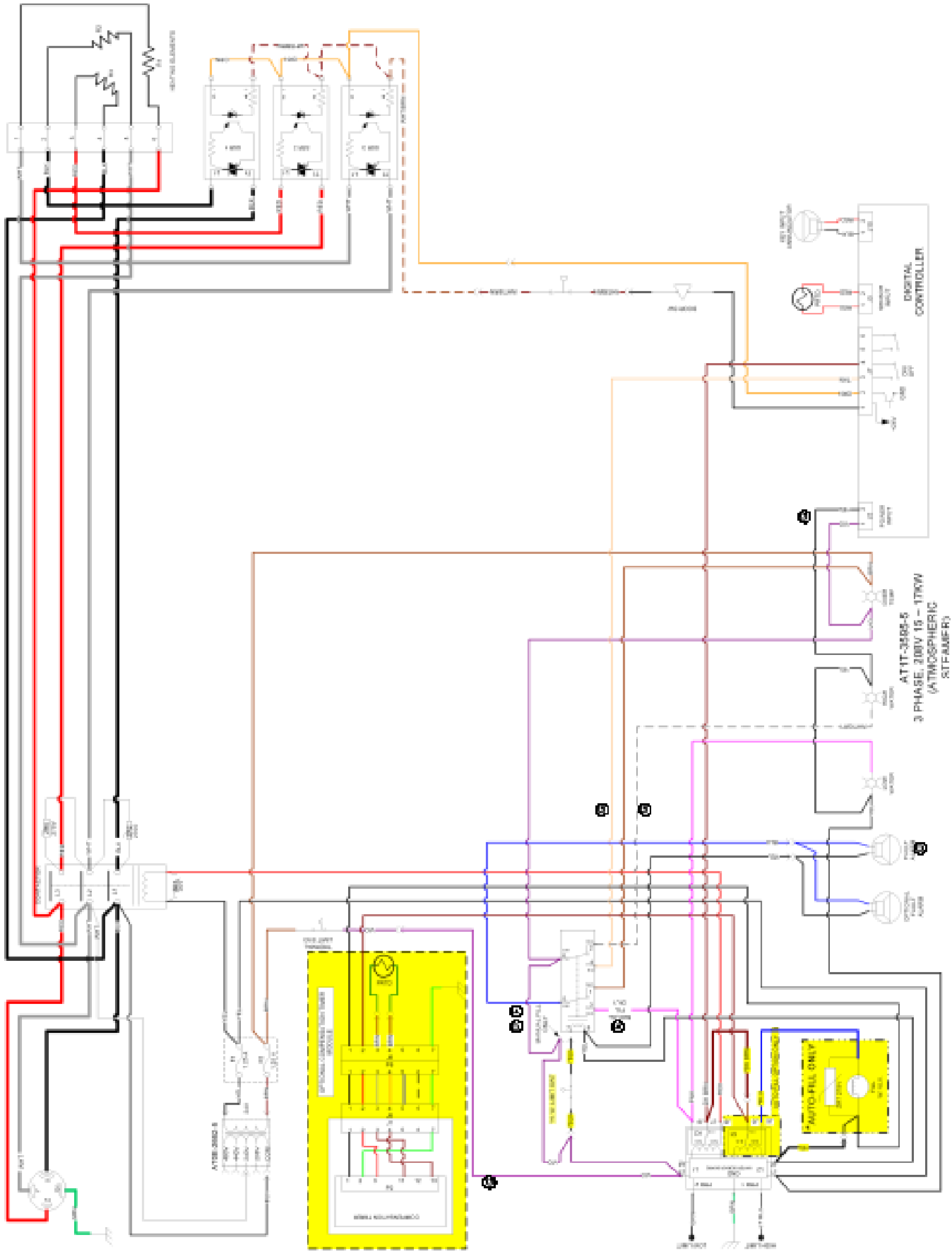

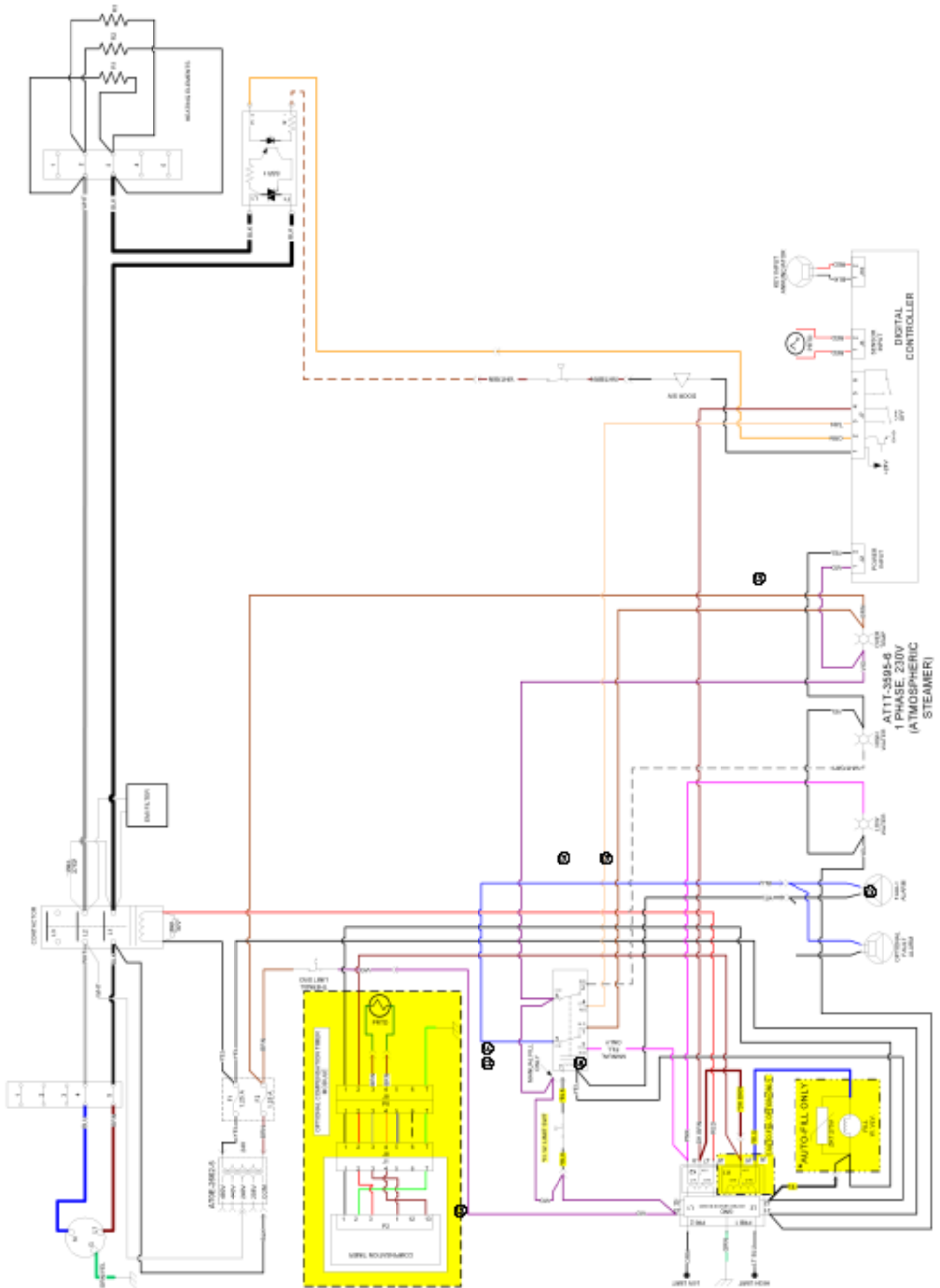

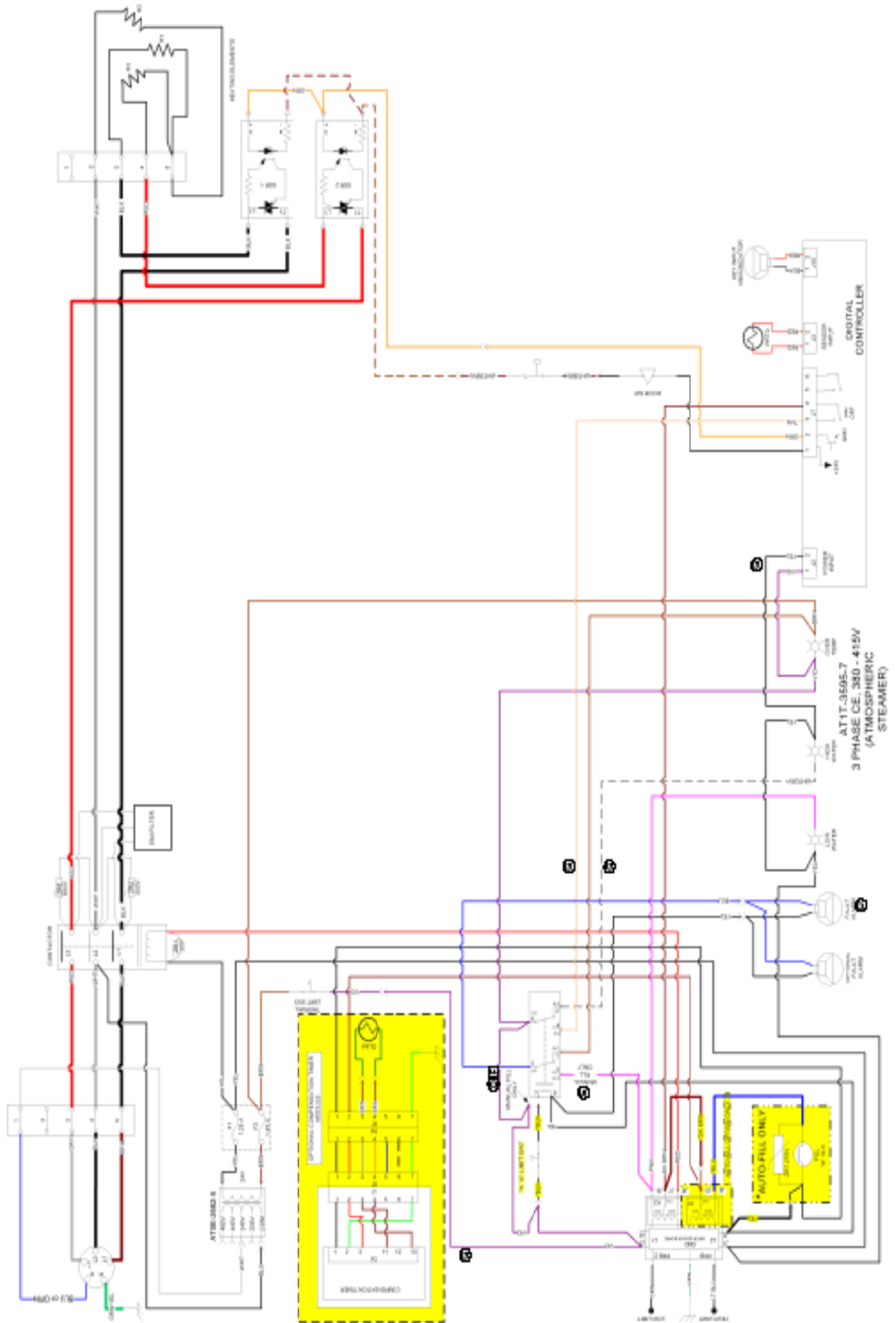

Blank Page

LIFETIMETM
SERVICE & SUPPORT
1-800-480-0415 | service@accutemp.net

UNMATCHED EFFICIENCY.
UNDENIABLE QUALITY.
UNBEATABLE SERVICE.

AccuTemp Products Inc.
Tel.: (800) 210-5907
www.accutemp.net